

Platinum **Q-Cut** User's Manual

**AUTOMATIC DIGITAL
CUTTING SYSTEM**



PLATINUM SERIES
Q CUT CUTTING SYSTEM

FOREWORD

Dear Customer:

Q-Cut series high precision digital cutting system can automatically complete the cutting, kiss cutting, carving, drilling, creasing, marking and so on. With automatic feeding and collecting system, jobs can be done quickly, which is also suitable for advertising signs, printing and packaging, automotive interior, furniture sofa, composite materials and other industrial production. It is the almighty champion of material cutting. Thank you for choosing Q-Cut high speed digital cutting system.

Here is our sincere hope and forever target for this production specification can be easily and comprehensively to be understood by you. In order to use this equipment properly, please read this user manual carefully and follow each step after reading. From the beginning to the end, Q-Cut “star service” will be accompanied by you, no matter what problem when you encounter, please check out the telephone number and address below and contact us. Here is our great honor and responsibility to serve you with any inquiries. Thank you again for choosing Q-Cut products, if there is any change for the manual contents due to product improvement, we apologize in advance that we won't make another notice.

Directory

1. Equipment Overview.....	1
1.1 Features.....	1
1.2 Composition.....	1
1.3 Working Principles.....	1
1.4 Technical Parameters.....	2
1.5 Cutting Head.....	3
1.6 Q-Cut Cutting Tools.....	4
1.7 Q-Cut Direction Information.....	7
1.8 List of Tools.....	8
2. Preparation.....	10
2.1 Installation Location.....	10
2.2 Personnel.....	10
2.3 Power Requirement.....	10
2.4 Environmental Conditions.....	11
2.5 Basic Device Compressed Air.....	11
2.6 Flooring Space Requirement.....	11
2.7 Operation Space Requirement.....	11
3. Installation.....	12
3.1 Opening and Inspecting Packing Crates.....	12
3.2 Setting Up The Base Frame Structure.....	13
3.3 Assemble The Cutting Beam.....	16
3.4 Installing The Vacuum Plates.....	17
3.5 Leveling The Table Plate.....	19
3.6 Advertising Industry: Installing The Regional Air Valves and PVC Pipes Images.....	22
3.7 Assemble The X Axis Side Covers.....	26
3.8 Pneumatic Control.....	28
3.9 Installing the Electric Box.....	30
3.10 Assemble main cable etc.....	31
3.11 Install The Conveyor Belt Guide Rollers Device.....	31
3.12 Install the AKI Device.....	35
3.13 Other Cables Function of Instructions.....	36
3.14 Assemble The Workstation.....	38
3.15 Install the Conveyor Belt.....	40
3.16 Tension the Conveyor Belt.....	42
3.17 Assemble the Milling Support Device.....	43
3.18 Install the Covers of The Front and Rear Side.....	48
3.19 Circuit Boards.....	49
4. Danger Areas During Initialization.....	50
4.1 Danger Area On the Module Carriage.....	50
4.2 Safety Device On the Machine and PC Table.....	51
5. Power and Air Supply Connecting.....	52
6. Cutting Head Installation.....	53
7. Tool Installation.....	55
8. Operation.....	61
8.1 Preparation.....	61
8.2 Steps.....	61
9. Maintenance.....	62

9.1 Daily Maintenance.....	62
9.2 Weekly Maintenance.....	63
9.3 Monthly Maintenance.....	65
9.4 Quarterly Maintenance.....	65
9.5 Annually Maintenance.....	65
10. Common Error and Troubleshooting.....	66
11. Safety Attentions.....	67
12. Other Information.....	67
12.1 Products Details.....	67
12.2 Warranty Card.....	67
12.3 Product Maintenance Details.....	68
12.4 Statement.....	68

1. Equipment Overview

Q-Cut Automatic Digital processing line can be used for full-time production, fulfilling the requirement of high efficiency, by using the maximum capacity of the machine to complete the 24/7 production.

1.1 Features

- Regional vacuum zone
- Vortex vacuum control
- Automatic sheet feeding
- Conveyor system
- Camera registration system
- High-speed and high-precision cutting tools
- Collection table for cutout elements picking
- No manual operation needed

1.2 Composition

Q-Cut series digital cutting machine series is composed of Electrical box, Main body, Vacuum and Auxiliary devices. Software includes file processing part and machine controlling part.

According to user's demand, one or more tools can be used: Tangent Tool, Oscillating Tool, Kiss-Cut Tool, Router, V-Cut Tool, Creasing Tool, Driven Rotary Tool, North & Drill Tool, Pen.

User can scan the bar code created by RIP software.



1.3 Working Principles

Import the files into SmartCut/iBrightCut, the user can process the files (editing and nesting) and send the processed cutting files to CutterServer. According to the cutting files, the controlling system will create motion control signals. With the signals, servo motors execute the tools lift/down and modules movement. Thereby, the machine achieves the high-speed and high-precision cutting

1.4 Technical Parameters

Definition	Parameter
Model	Q-Cut 2521 (Q-Cut 2521 is just one model, more dimension is available) .
Cutting Area	2500*2100 mm (98.4 inch *82.6 inch)
Machine Dimension	3340*3000*1273 mm (131.4 inch *118.1 inch *50.1 inch)
Weight	1550 kg
Vacuum Zones	3 - 24
Max Speed	1500mm/s (59inch/s)
Accuracy	0.1mm
Max Cutting Thickness	50mm (1.96 inch)
Modules	Can be installed up to 3 cutting heads
File Formats	DXF、PLT、PDF、HPG、HPGL、TSK、BRG、XML、CUT、OXF、ISO、 AI、PS、EPS
Interface	Serial Port / USB Port
Adsorption	Vacuum Pump
Power	Single-phase 220V / 2KW (exclude the power of feeder)
	Three-phase 220V/380V 5.5KW/7.5KW*n (n is the quantity of vacuum zone, exclude the power of feeder)
Power Requirement	220V/50/60HZ、380V/50/60HZ (Three-phase five-wire system)
Air Pressure Requirement	0.6~0.85MPa, Dry compressed air
Operating Environment	Temperature: 0°C-40°C ; Humidity: 20%-80%RH
Storage Temperature	- 20 to + 55°C

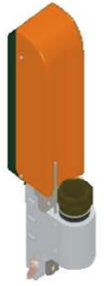
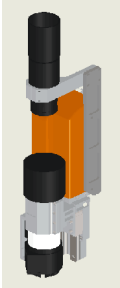
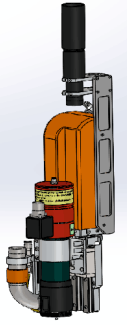
1.5 Cutting Head

	<p>Q-Cut Universal Cutting head</p>	<p>All tools can be installed in (except 1KW router)</p>	<p>Cutting thickness: 50mm</p>
	<p>1.8KW Router</p>	<p>Power: 1.8W 60000rpm water cooling cleaning device</p>	<p>Cutting thickness: 2mm-6mm Di-bond 20mm Acrylic</p>
	<p>1KW Germany Router</p>	<p>Power: 1KW 60000rpm Air cooling cleaning device</p>	<p>Cutting thickness: 2mm-6mm Di-bond 20mm Acrylic</p>
	<p>Q-Cut-Marking head</p>	<p>Two pens 3 times/s/pen</p>	<p>Material thickness: 50mm</p>
	<p>Q-Cut-North & Drill head</p>	<p>Two heads 3 times/s/head</p>	<p>Material thickness: 10mm</p>

1.6 Q-Cut Cutting Tools





Illustration	Name	ab.	Feature	Materials
	Tangent Tool	CUT	Universal Cutting Tool for materials up to 5mm thick. Fast speed and low cost.	Cardboard, Chevron board, ABS board, Gasket, Carbon fiber prepreg, PVC tarpaulin, PE, XPE, Label, etc.
	Electric Oscillating Tool	EOT	High-frequency electric-driven tool with 80W power options. Max cutting speed 1m/s for soft and medium-density materials.	Chevron board, Corrugated board, Gasket board, Gray cardboard, PE, XPE, EPE, PU leather composite sponge, Coil car mat, etc.
	Pneumatic Oscillating Tool	POT	Powerful air-driven tool with extended stroke for dense materials up to 50mm thick.	Composites, Honeycomb board, Asbestos gasket, Graphite gasket, Sponge, EPE, etc.
	Kiss-Cut Tool	KCT	Half-cut tool for vinyl materials.	Vinyl, sticker, reflective film, etc.
	Driven Rotary Tool	DRT	Cutting tool with driven rotary blade for fabrics and technical textiles with high processing speed.	Fabrics, carbon fiber, glass fiber, aramid, carpet, etc.





Illustration	Name	Ab	Feature	Material
	V-Cut Tool	V-CUT	Tool with 5 cutting angles (0°,15°,22.5°, 30°, 45°). Create 3D structural design.	Honeycomb board, sandwich board, KT board, Gray board, etc.
	Powerful Rotary Tool	PRT	Powerful tool with driven rotary blade.	textiles, carbon fiber, glass fiber, carpet, fur, etc.
	Creasing Tool	CTT	Creasing wheels for carton box making	Corrugated board, carton board, etc.
	CNC Router	MILL	Routing tool with high-performance routing on hard and tough materials up to 16mm thick. Power: 350W; RPM:60000rpm; Max thickness:16mm.	Acrylic, Di-bond, aluminum composite, MDF, etc.
	CNC Router	MILL 1KW	Routing tool with high-performance routing on hard and tough materials up to 20mm thick. Power: 1KW; RPM:60000rpm; Max thickness:20mm.	Acrylic, Di-bond, aluminum composite, MDF, etc.

Illustration	Name	Ab	Feature	Material
	CNC Router	MILL 1.8KW	Routing tool with high-performance routing on hard and tough materials up to 20mm thick. Power: 1.8KW; RPM:60000rpm; Max thickness:20mm.	Acrylic, Di-bond, aluminum composite, MDF, etc.
	Electric Oscillating Tool	EOT3	High-frequency electric-driven tool with 200W power options. Max cutting speed 1m/s for soft and medium-density materials.	Chevron board, Corrugated board, Gasket, KT board, Gray cardboard, PE,XPE,EPE,PU leather, PU composite sponge, Coil car mat, etc.
	Super Powerful Rotary Tool	SPRT	Super Powerful tool with driven rotary blade.	textiles, carbon fiber, glass fiber, carpet, fur, etc.
	Perforating tool	PTK	Perforating tool	KT board, Corrugated cardboard, paperboard, cardboard, etc
	Universal drawing tool	UDT	Universal drawing tool	Stencils, technical labeling ,labeled paper,etc,

1.7 Q-Cut Direction Information

Directions such as "right, left" or "front, back" depends on the operator's view of the machine during operation.

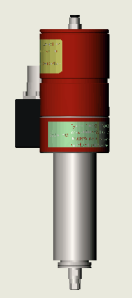
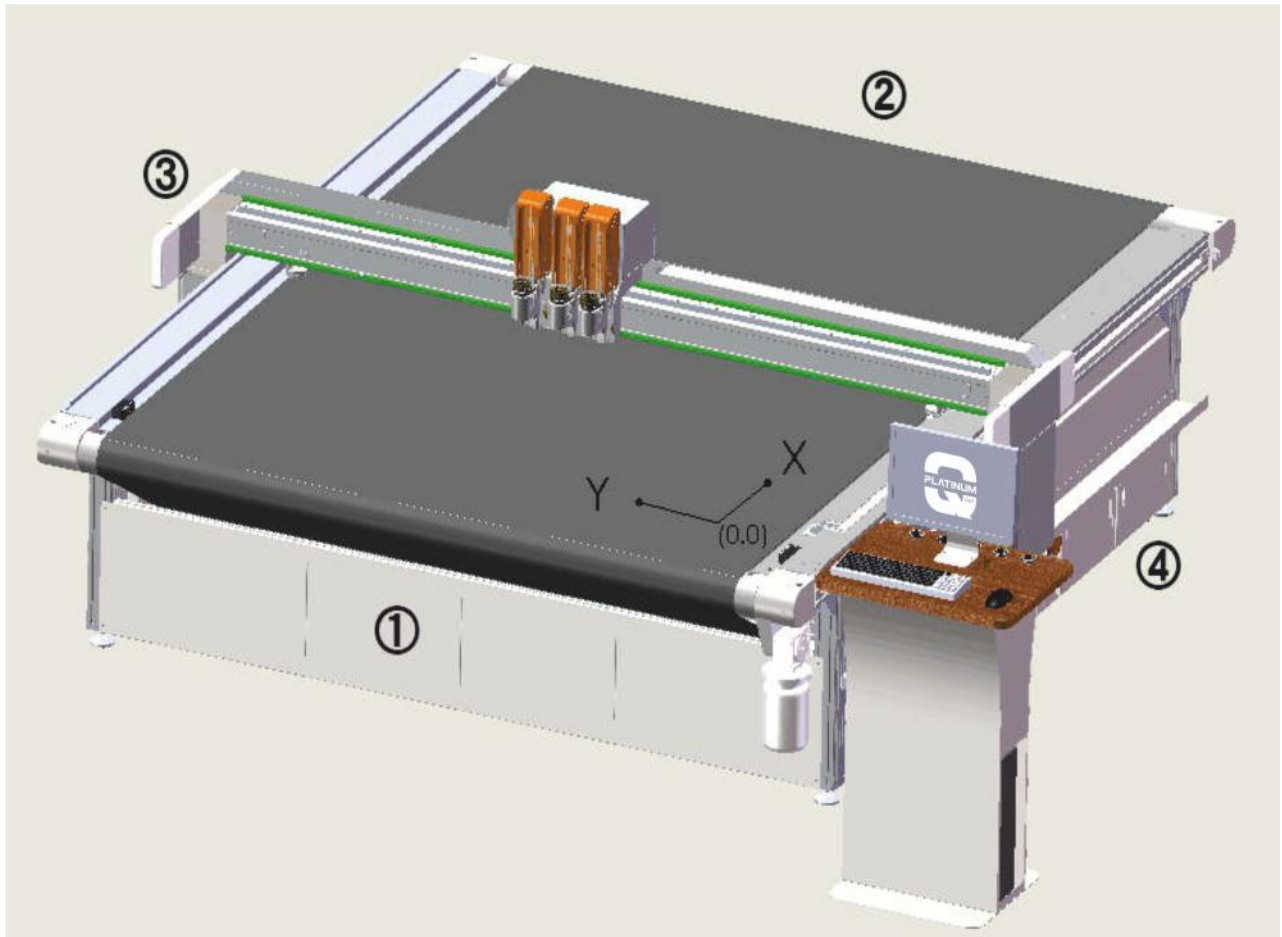

1 front
2 back
3 left

4 right
x X-axis
Y Y-axis

1.8 List of Tools







Illustration	Description	Function
	A set of Allen keys (SW 1.5 to 8)	
	Various open-ended spanners (SW 5.5-19.2x10)	
	various Phillips and slotted screwdrivers	
	screwdriver	
	Ratchet set with bolt nuts and Allen inserts	
	Dial gauge (resolution of 0.1 mm)	To align the table plate

Illustration	Description	Function
	Holder for supporting dial gauge	Table plate: set height
	Electric drill	
	Side cutters	to open the transport locking devices
	Measuring tape	
	Precision spirit level (recommended value 0.05 mm/m)	To level the machine
	Precision spirit level	To level the machine foot

2. Preparation

2.1 Installation Location

Make sure that the following requirements are met:

- the installation location is level and can withstand the floor loads.
- the transportation routes to the installation location do not include steps or staircases.
- the shipping crates can be deposited close to the installation location and their presence does not prevent the machine from being assembled.
- the aisle width from the unloading location to the installation location is at a minimum the width required for the dimensions of the packing crates.
- the electrical and air connections meet the requirements listed in the technical data.
- the installation location is well-lit.
- At least 1 meter of space is available all around the cutting system for service and daily operation.

2.2 Personnel

Make sure that the following requirements are met:

- the support personnel wear safety clothing and work gloves.
- the support personnel are familiar with the hazards associated during machine installation and have read and understood the mounting instructions.

2.3 Power Requirement

Three-phase Vacuum Pump	Voltage	Electric Current	Air Circuit Breaker	Wire Size	Wiring System
5.5KW	380V	8.3A	20A	6mm ²	L1、L2、L3、N、G
7.5KW	380V	12A	20A	6mm ²	L1、L2、L3、N、G

Three-phase Vacuum Pump	Voltage	Electric Current	Air Circuit Breaker	Wire Size	Wiring System
5.5KW	220V	14.5A	30A	6mm ²	L1、L2、L3、G
7.5KW	220V	20A	50A	8mm ²	L1、L2、L3、G

Single-phase Machine & PC	Electric Current	Aircircuit Breaker	WireSize	Wiring System
220V	10A	15A	6mm ²	L、N、G

2.4 Environmental Conditions

	Value	Unit
Operating temperature	+ 10 to + 35	°C
Storage temperature	- 20 to + 55	°C
Relative humidity	10 - 80, non-condensing	%

2.5 Basic Device Compressed Air

Conveyor feeding clamps	Value	Units
Operating pressure	0.6	MPA
Min. air flow	0.4	m ³ /min
Control of POT tool, supply of 1KW,1.8KW Router	Value	Units
Operating pressure	0.85	MPA
Min. air flow	0.6	m ³ /min

2.6 Flooring Space Requirement

Machine Dimension Length X Width (with router, the height of regular route holder is 2.8meter)

Material loader	Length / width	Tk3S
With	Length	Length+1.9m
	Width	Width+0.9m
Without	Length	Length+0.9m
	Width	Width+0.9m

2.7 Operation Space Requirement

Machine Dimension: Length X Width (with router, the height of regular route holder is 2.8meter)

Feeding Frame	Length / width	Tk3S
With	Length	Length+3.4m
	Width	Width+2.4m
Without	Length	Length+2.4m
	Width	Width+2.4m

3. Installation

3.1 Opening and Inspecting Packing Crates



Note:

Prevent the crate cover from warping when placed at an angle. Place the packing crate level.



Note:

- Only complete the installation if all parts are present and undamaged.
 - Inform Q-Cut customer service if any parts are missing or damaged.
 - Replenish or replace missing or damaged parts.
-

- A** Remove all screws on the upper side of the packing crate.
- B** Remove the cover and place it to one side.
- C** Remove the screws from the upper crossbars
- D** Remove the crossbars and place them to one side
- E** Loosen the screws of the side cover.
- F** Remove the side cover.
- G** Make sure the contents are complete and without damage.

3.2 Setting Up the Base Frame Structure

3.2.1 Framework

The components consists of the left beam, right beam and under frame.

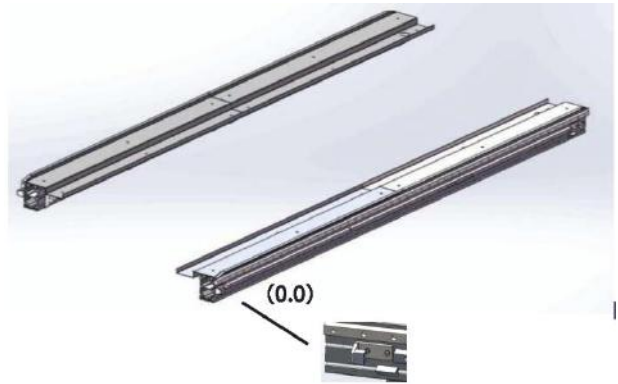
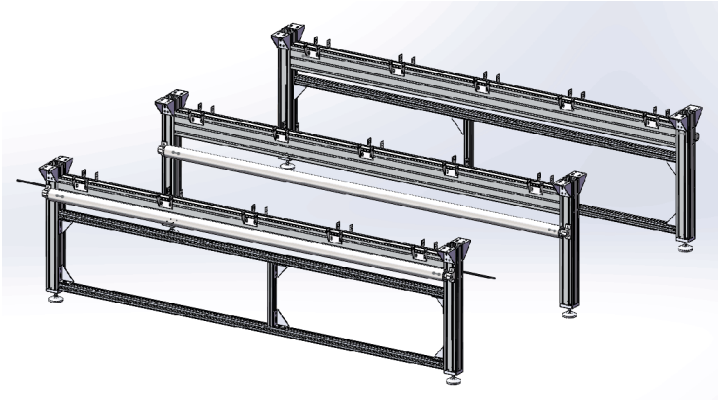

1. Front foot (including pause cable)
2. Middle foot
3. Rear foot

Left / Right



Note:

Assemble the left and right beam under frame as below, fasten tightly T-bolts(M8x25mm) with glue, set up the framework, meet the following requirements:

1. Both side of the end surface distance: 200 ± 2 mm, adjust the distance between each legs component: 1180 ± 2 mm.
2. Make sure the diagonal dimensions are less than 2 mm.

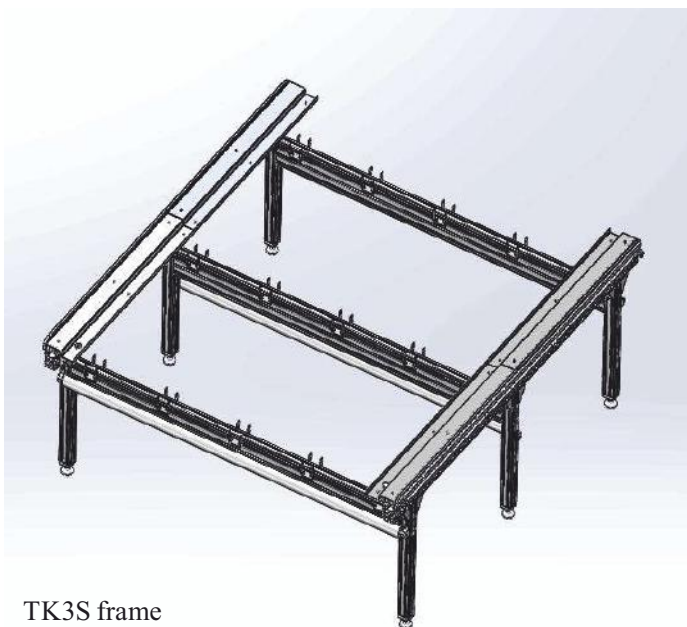

TK3S frame

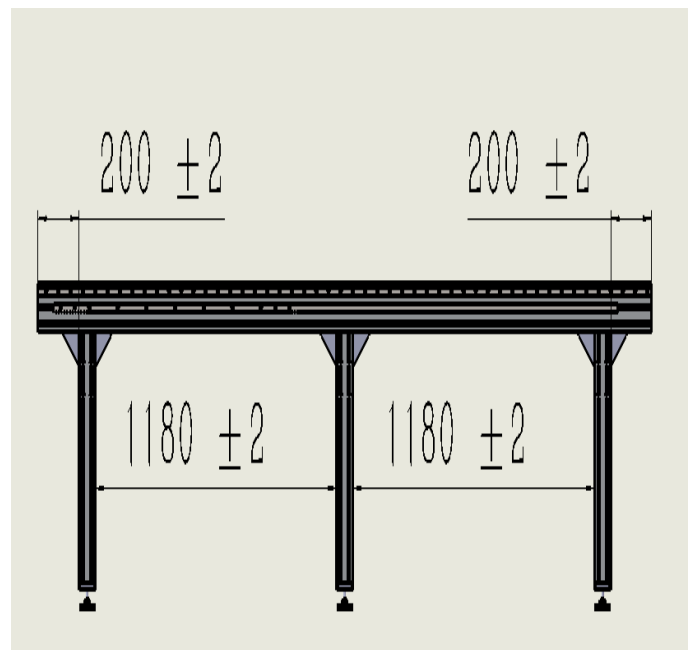

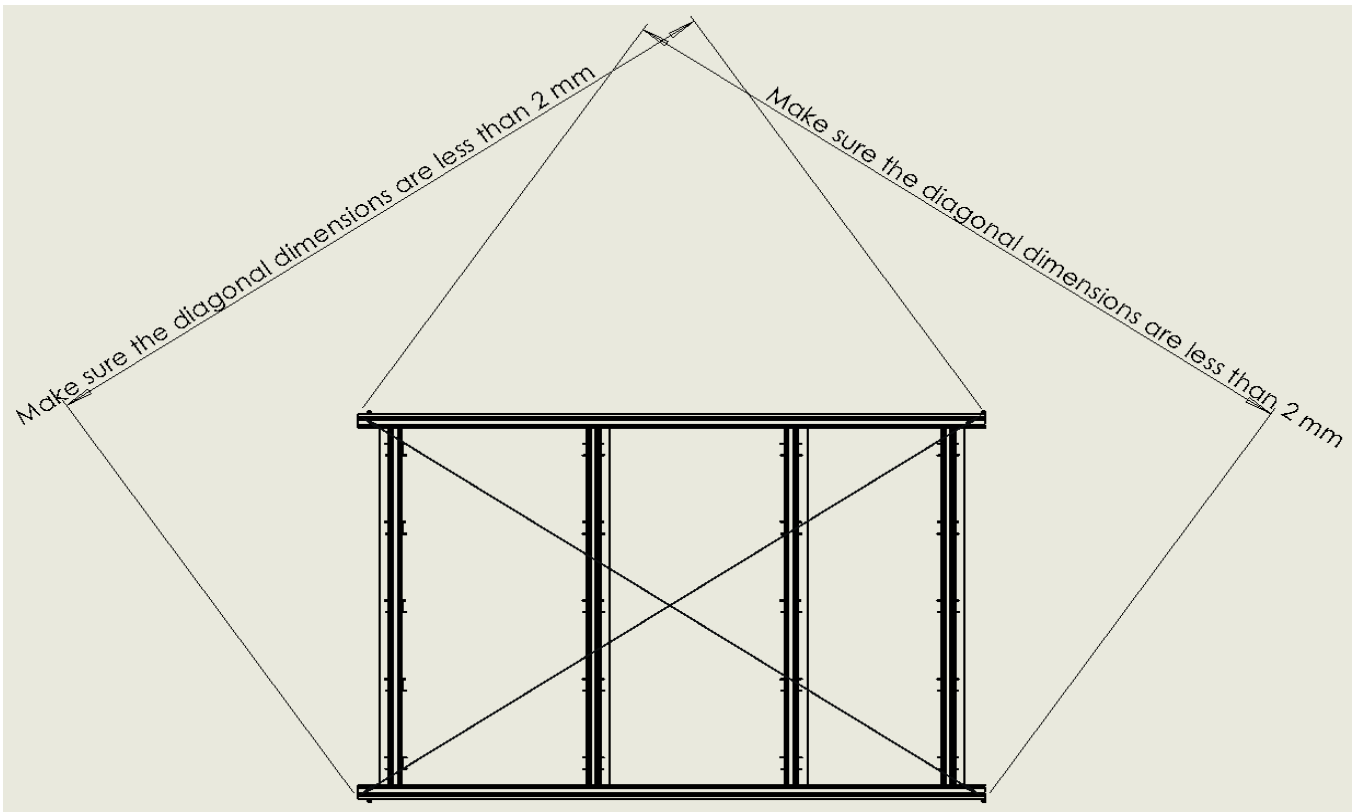

3.2.2 Initial leveling of the base frame

- A** Lift each side support end to keep the balance by precision spirit level.
- B** Determine the lowest position of the foot and use the setscrews to adjust it upwards.
- C** Use the setscrew to raise the position of the lowest foot.

3.2.3 Connecting the Pause cables

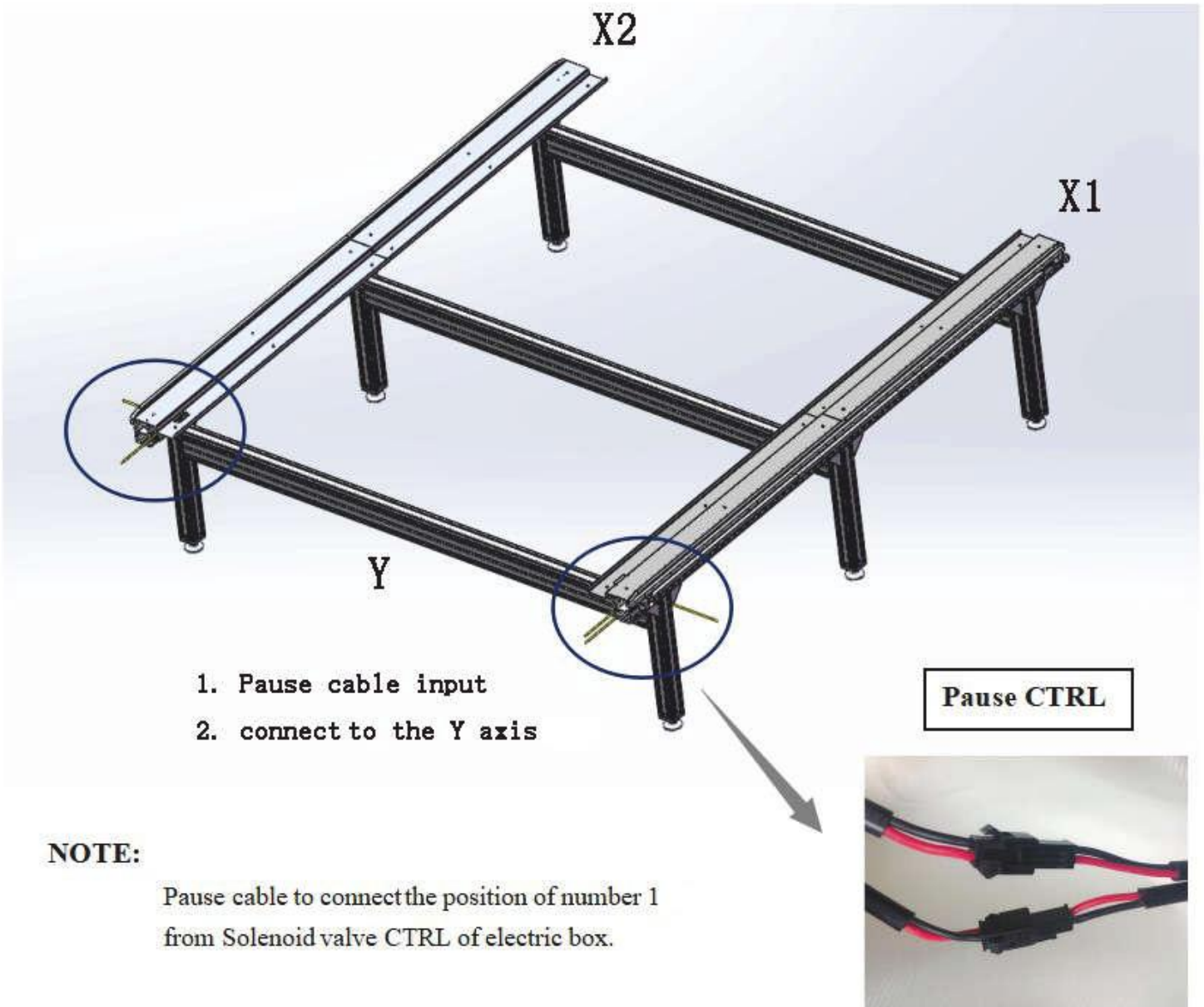

3.3 Assemble the Cutting Beam

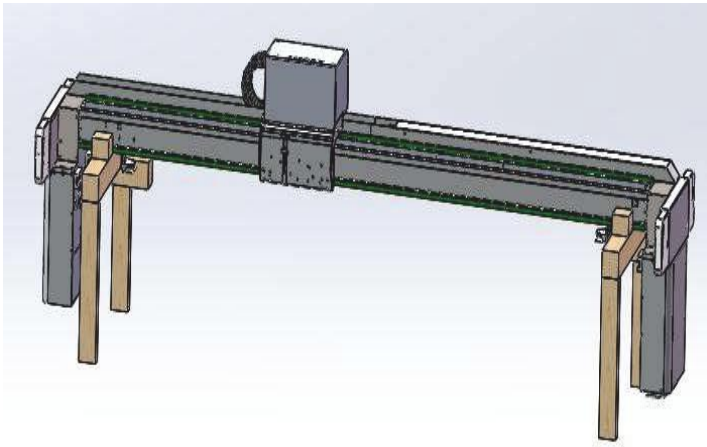

Beam

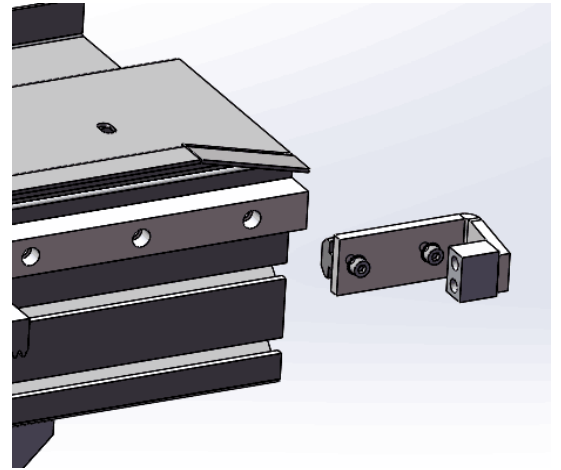

Block slider



Pay attention:

Keep balance from rear side when assembling the cutting beam, carefully take out the plug in the slider, put the cutting beam onto the side beams, make sure that the pen holder faces to the photoelectric plate.

After assembly, put the block slider back and then tighten the screws.

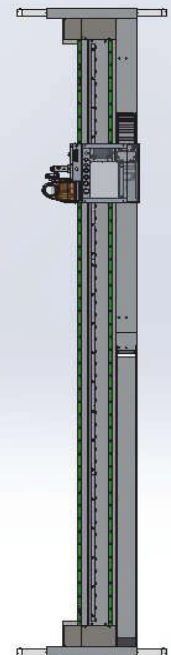
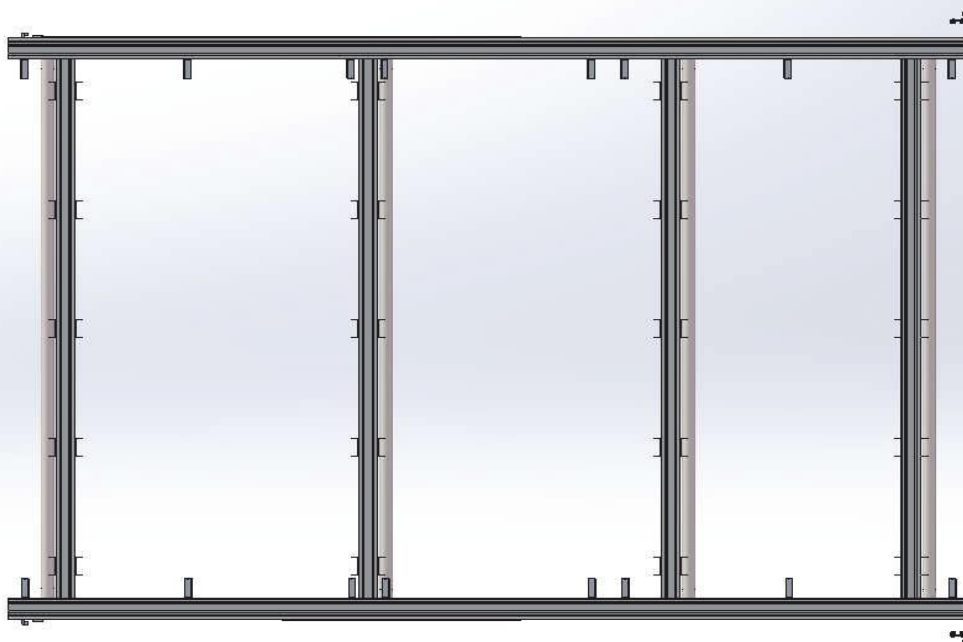

3.4 Installing the Vacuum Plates

Note:

The bracing tube and vacuum plates are labeled. The order must be followed! The label must always be positioned at the front!



Attaching bracing tube X1 :

Place bracing tube X1 to X5

The two end of the square pipe extended 120mm long from the aluminum frame

Tighten the screws(M8x12mm) and washer.

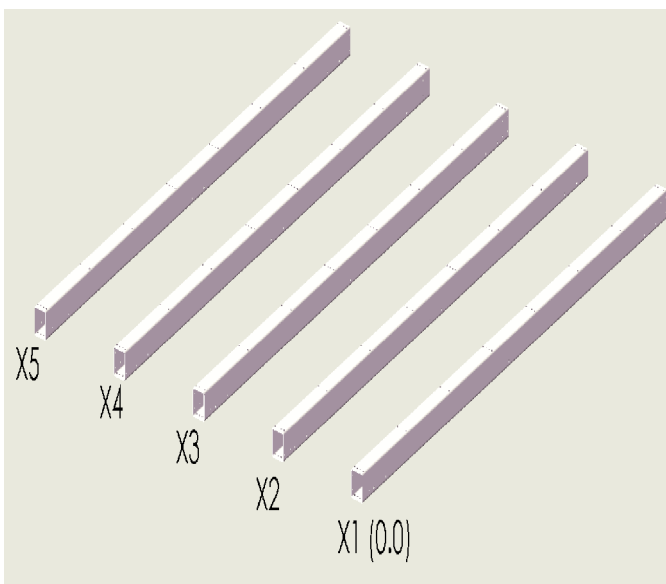

Aluminum tubes

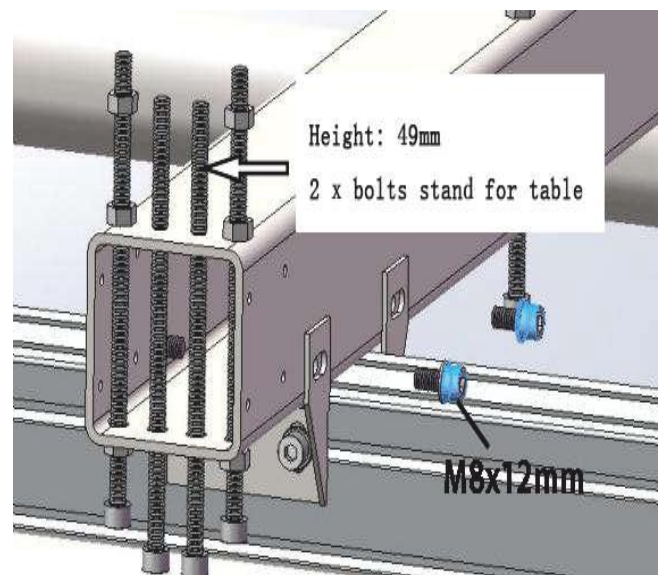

Screws

3.3.2 On the basis of frame work, assemble the aluminum table

Aluminum table

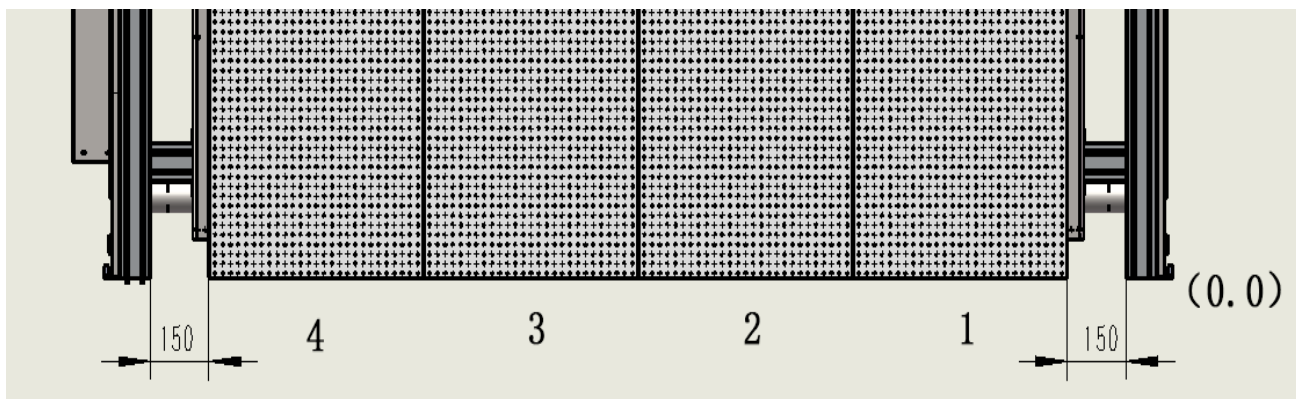
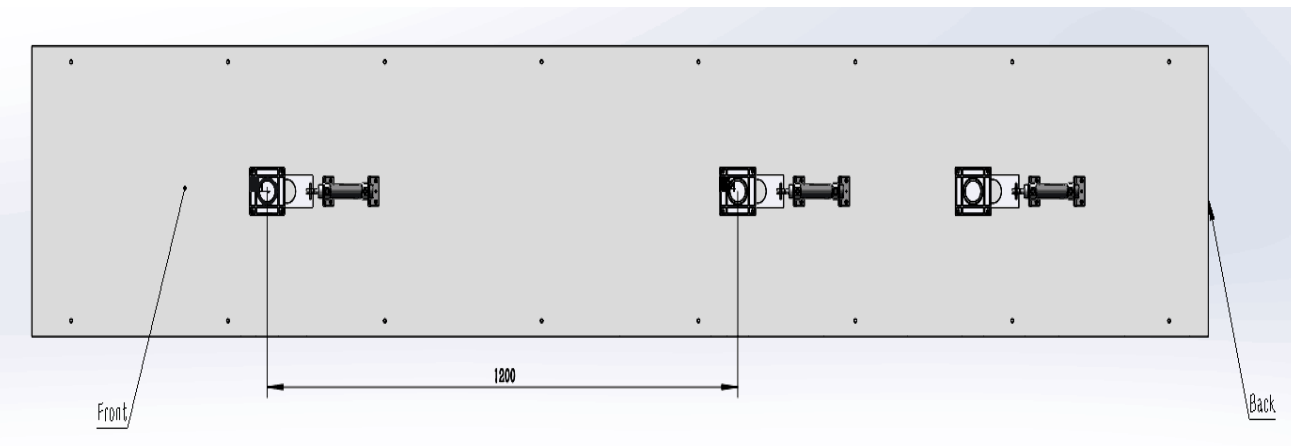
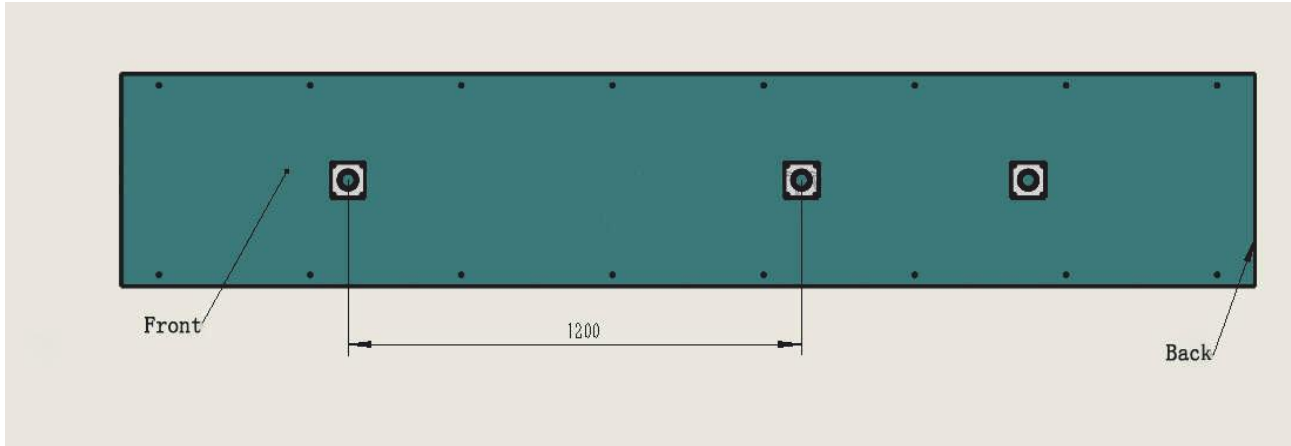

The cutting table is made up by certain pieces of aluminum plate.

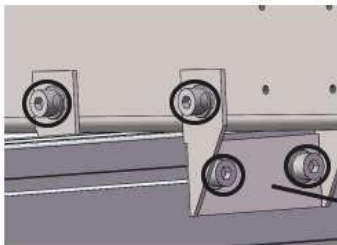
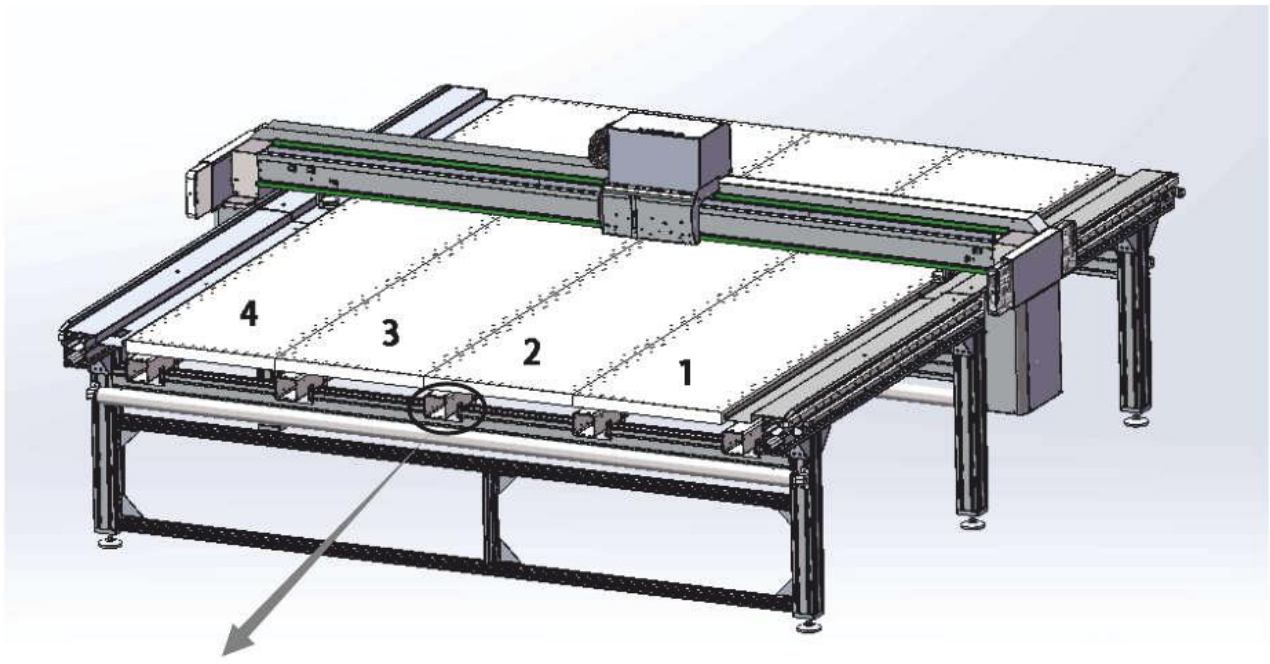

You can adjust these parts if necessary to adjust the position of the table panel.

M8x12mm

3.5 Leveling the Table Plate

Settings accuracy: ± 0.2 mm/m

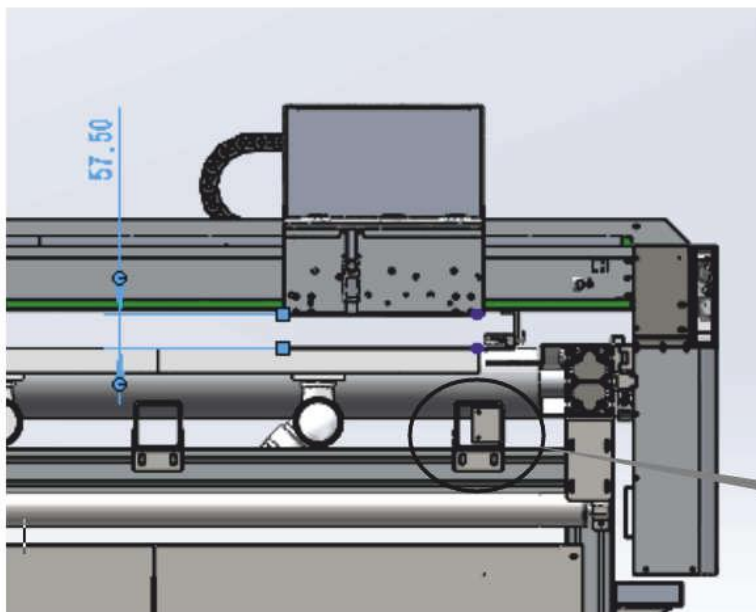

Measure the distance from the bottom of the Module carriage to the surface of the aluminum platform with a steel ruler is $57.5\text{mm} \pm 0.5\text{mm}$.



3.5.1 Mount the dial gauge on the module carriage

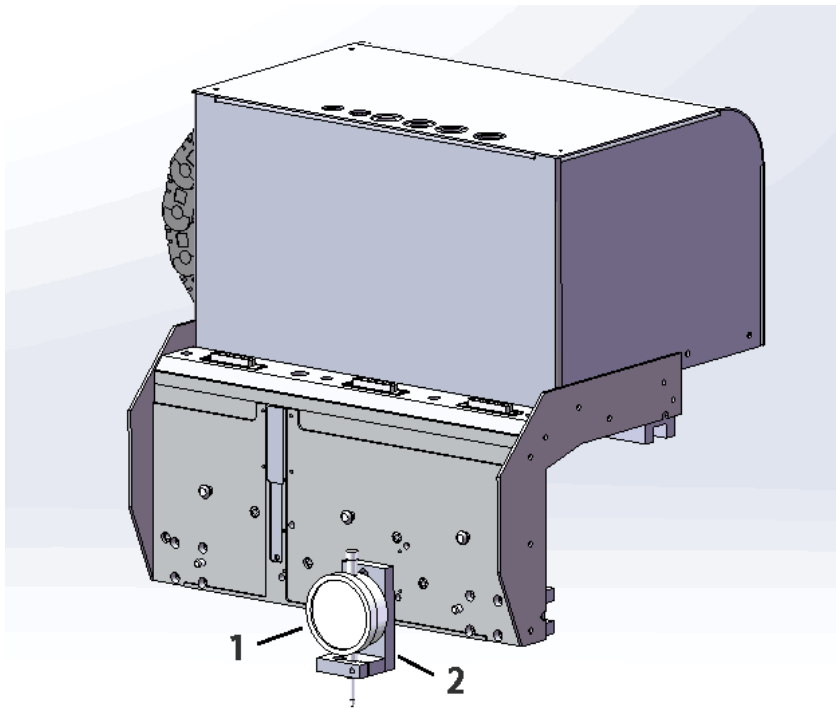

1 Dial gauge

2 Dial gauge support

- Fasten the dial gauge support to the module carriage
- Insert the dial gauge
- Starting from the front right-hand side, set all plates to the same level. Align the vacuum plates

3.5.2 Adjusting the vacuum plate height.

Adjusting steps : 1 - 2 - 3

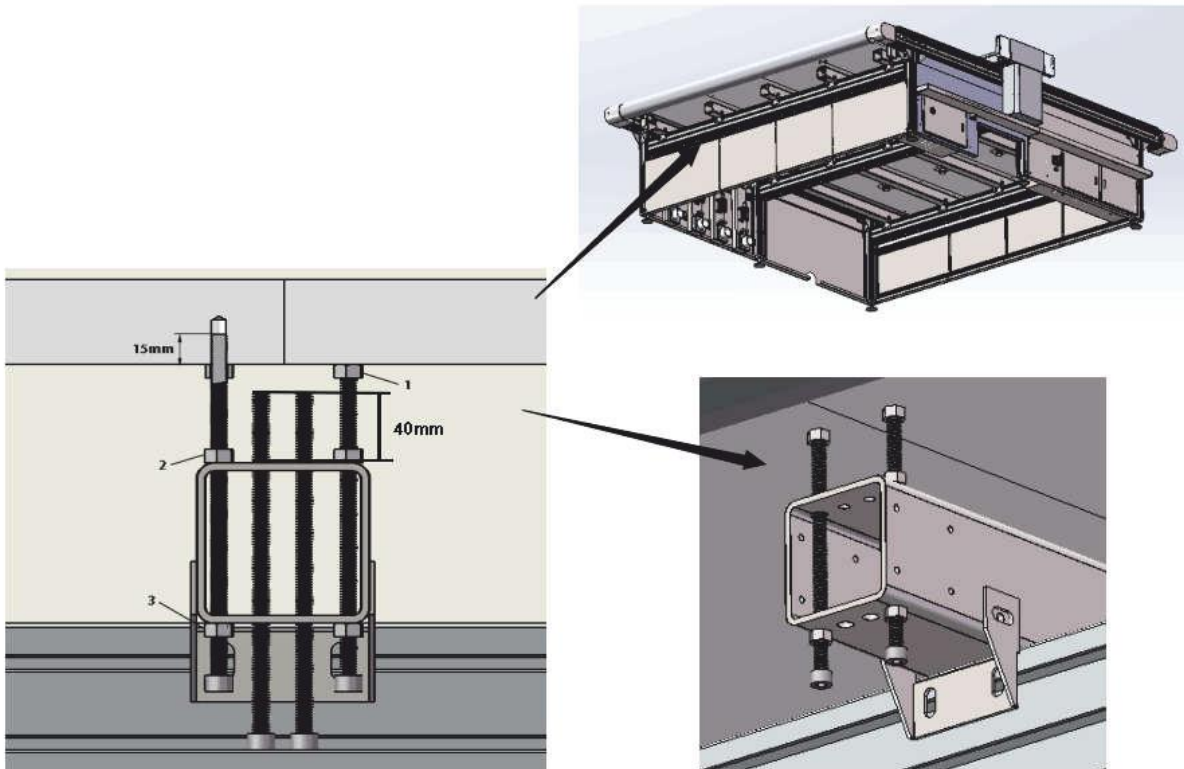

Note:

An assistant must read the dial gauge and provide information about the current height.

After adjusting the vacuum plate, remove the mounting bolts for stand table.

- Use the module carriage to move from fastening point to fastening point and measure the deviation.
- Tighten the screw (1) under the table.
- Loosen the screw (2).
- Adjust the screw (2) (3) until the table surface height matches the calculated height (front right) (0.0) position.
- Tighten the screw (2) (3)
- Repeat this adjustment procedure at all positions.
- Check the alignment by taking measurements for all vacuum plates and readjust as necessary.
- Remove the dial gauge and its holder from the head carriage.

3.6 Advertising Industry: Installing the Regional Air Valves and PVC Pipes Images.

Dot matrix or matrix is chosen according to the application industry.

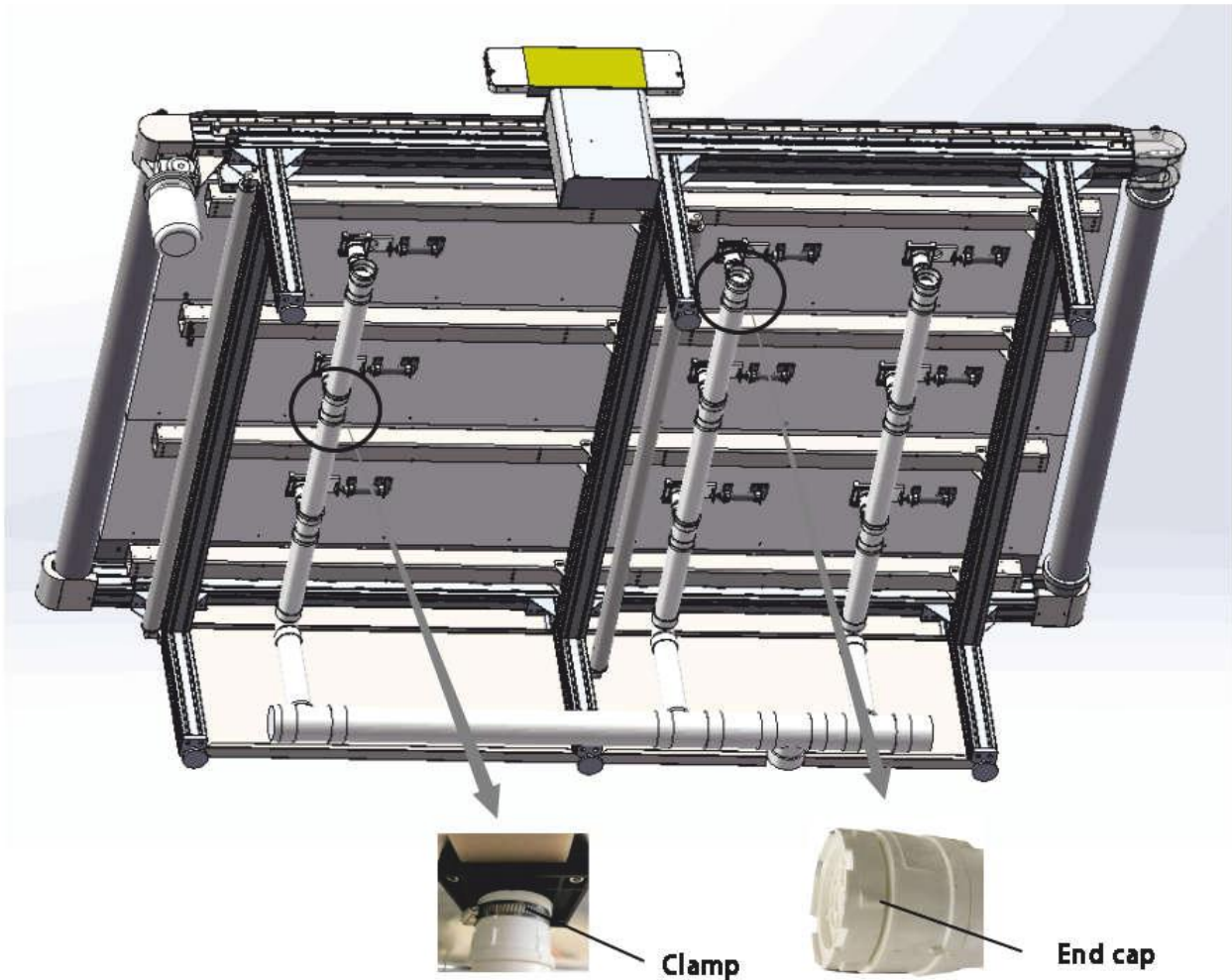

A The PVC pipes are labeled, the order must be followed!

B Do up the straps.

C Fasten the piping system to the cutter by using glue, clamps and cable ties.

Install regional air valves and PVC pipes

Dot matrix or matrix is chosen according to the application industry.

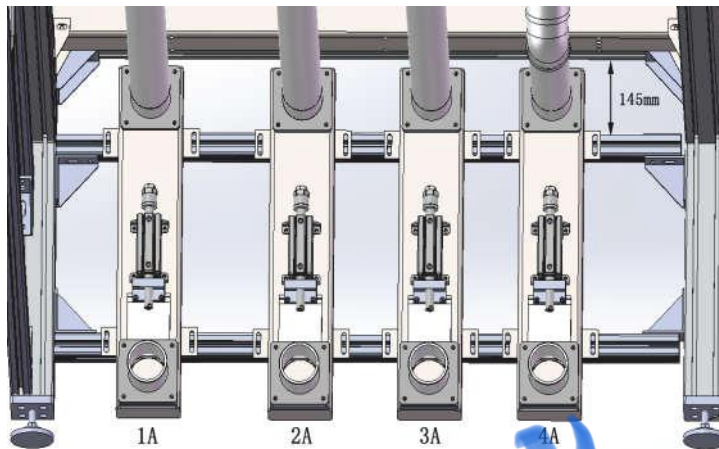

Regional air valves

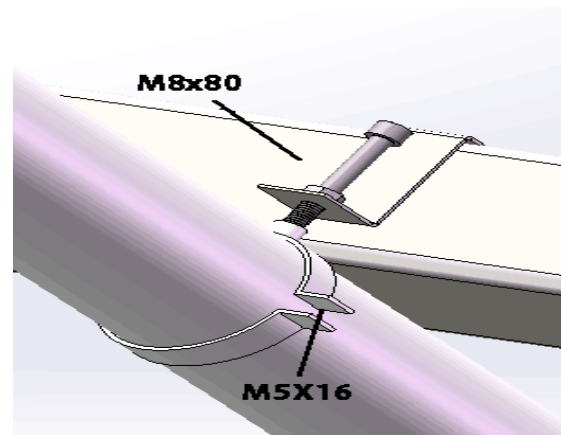

Bracket for holding the tubes

On the other side of the zero point, assemble the regional valves firstly, and then PVC pipes.

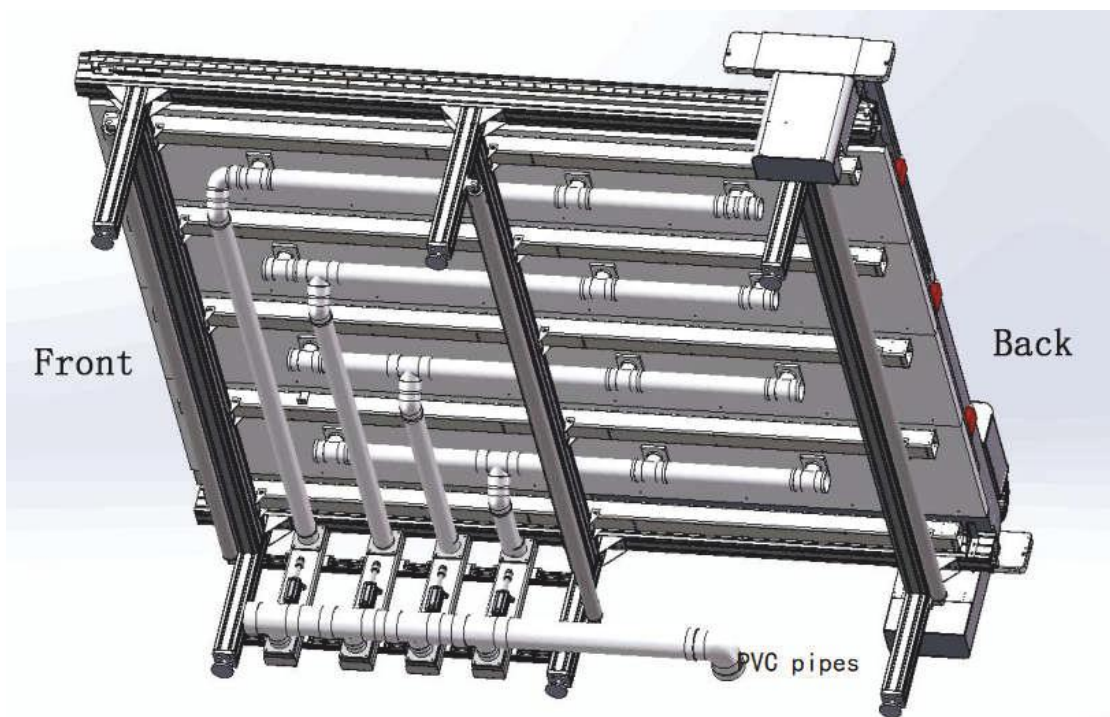

- A** The PVC pipes are labeled ,the order must be followed!
- B** 1A --- 1H 2A --- 2H 3A --- 3H 4A --- 4H
- C** Do up the straps.
- D** Fasten the piping system to the cutter by using glue, hoops and cable ties.

Attaching the vacuum pipe to the vacuum pump system

5.5/7.5 KW vacuum pump with changeover valve

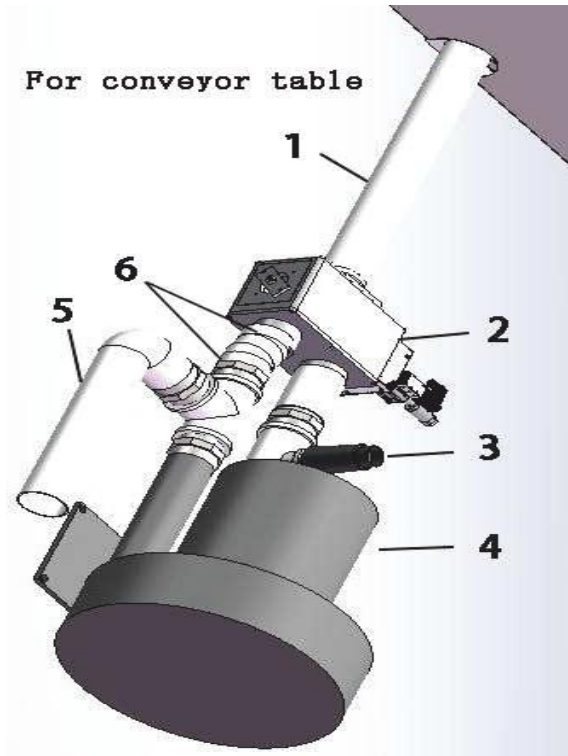

5.5/7.5KW vacuum pump

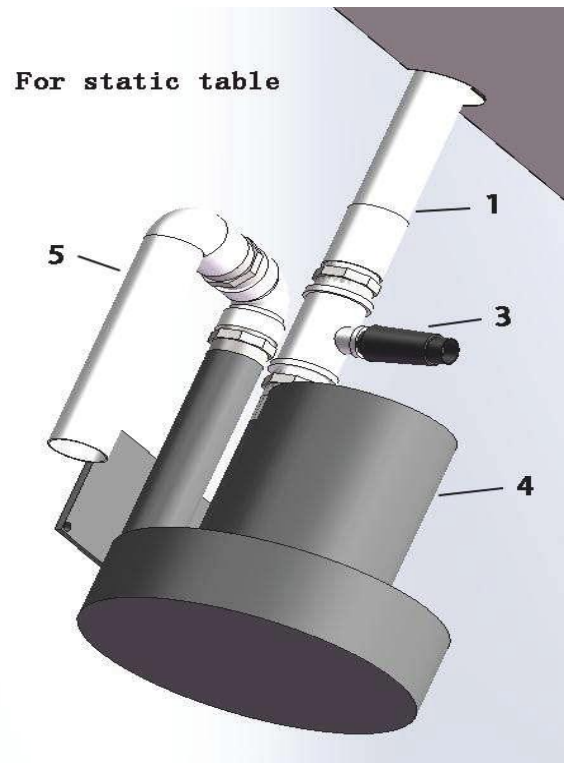

- 1 Hose to cutter
- 2 Changeover valve
- 3 pressure release valve

- 4 Vacuum pump
- 5 Silencer
- 6 Clamp

- A** Set up the vacuum pump.
- B** Fit the silencer.
- C** Connect the vacuum pump to the cutter using the hose.
- D** Turn the piping outwards

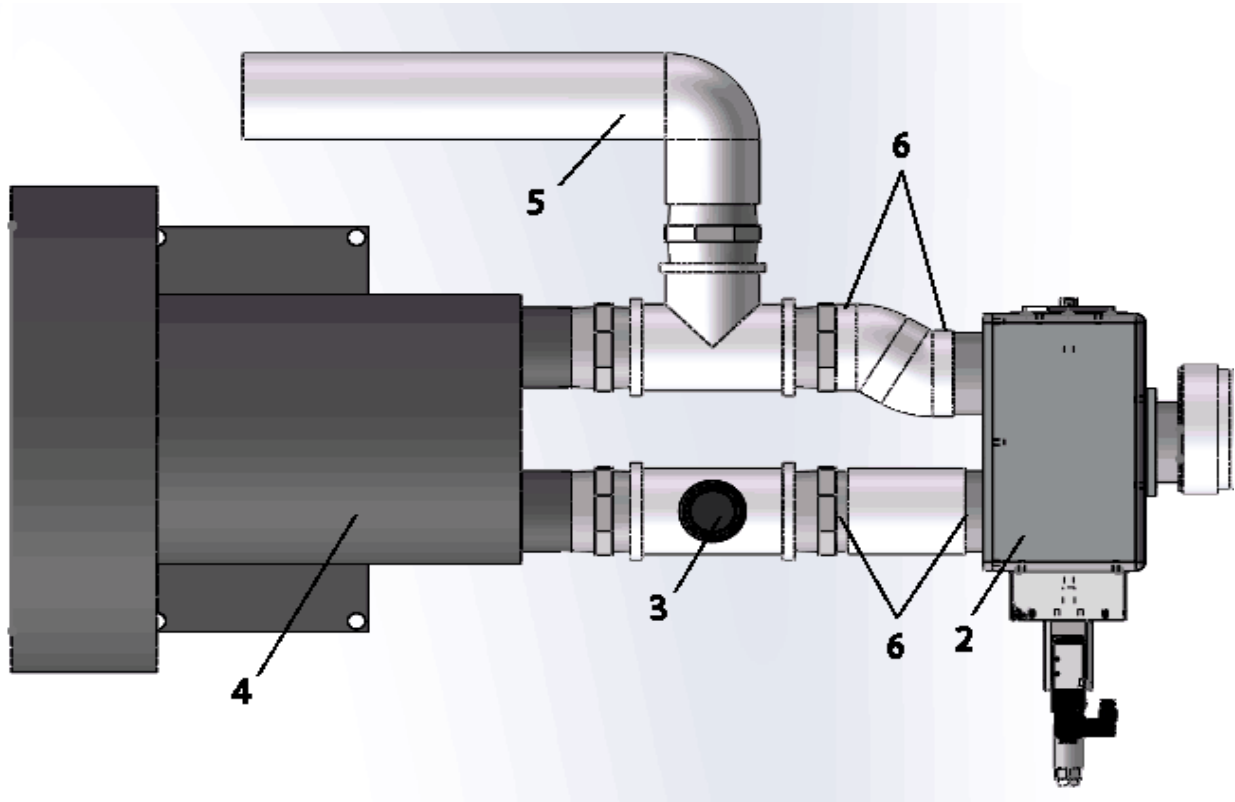

- | | | | |
|---|------------------------|---|----------|
| 2 | Changeover valve | 5 | Silencer |
| 3 | Pressure release valve | 6 | Clamp |
| 4 | Vacuum pump | | |



- Note:
1. Connect changeover valve cable (Q-Cut) to electromagnetic Valve controller in electric box
 2. Connect air tube $\Phi 4\text{mm}$ to the regional air control box
 3. Connect vacuum pump cable to frequency converter box

3.7 Assemble the X Axis Side Covers.

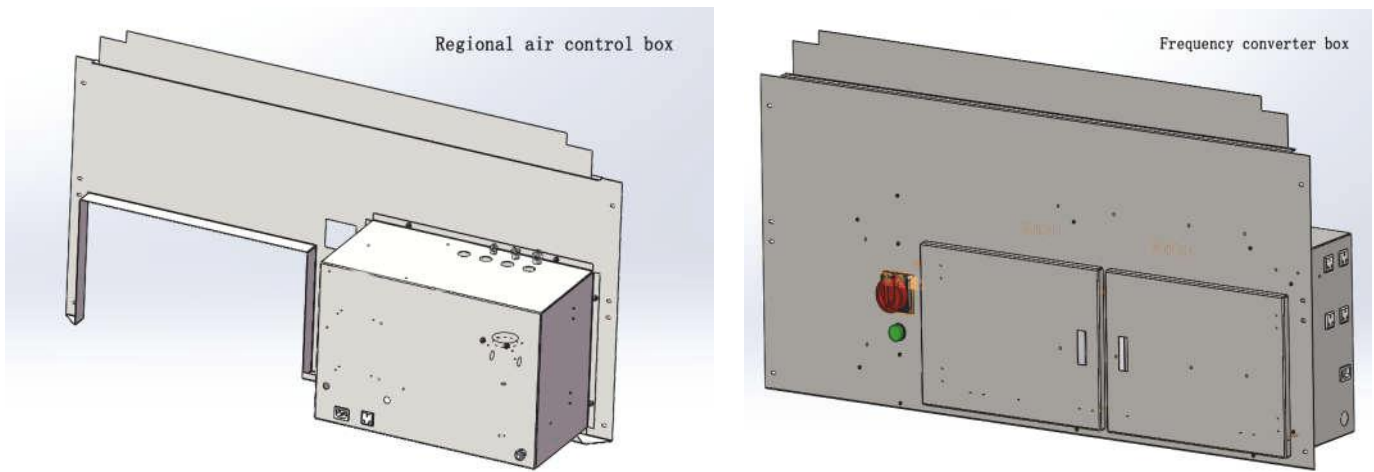

Note:

Covers for regional air control box and covers for frequency converter are on the side of X axis of zero point. The other two covers with same size assembled on the other side.

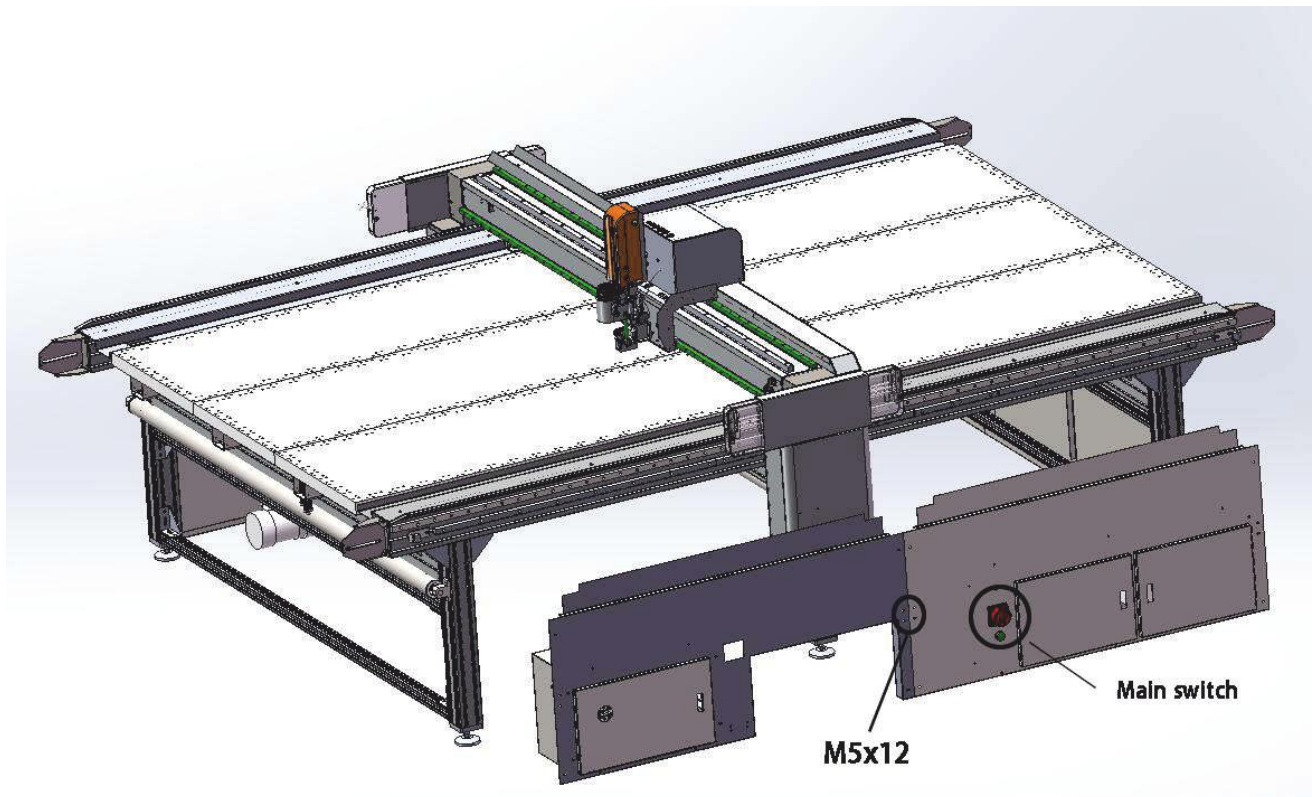

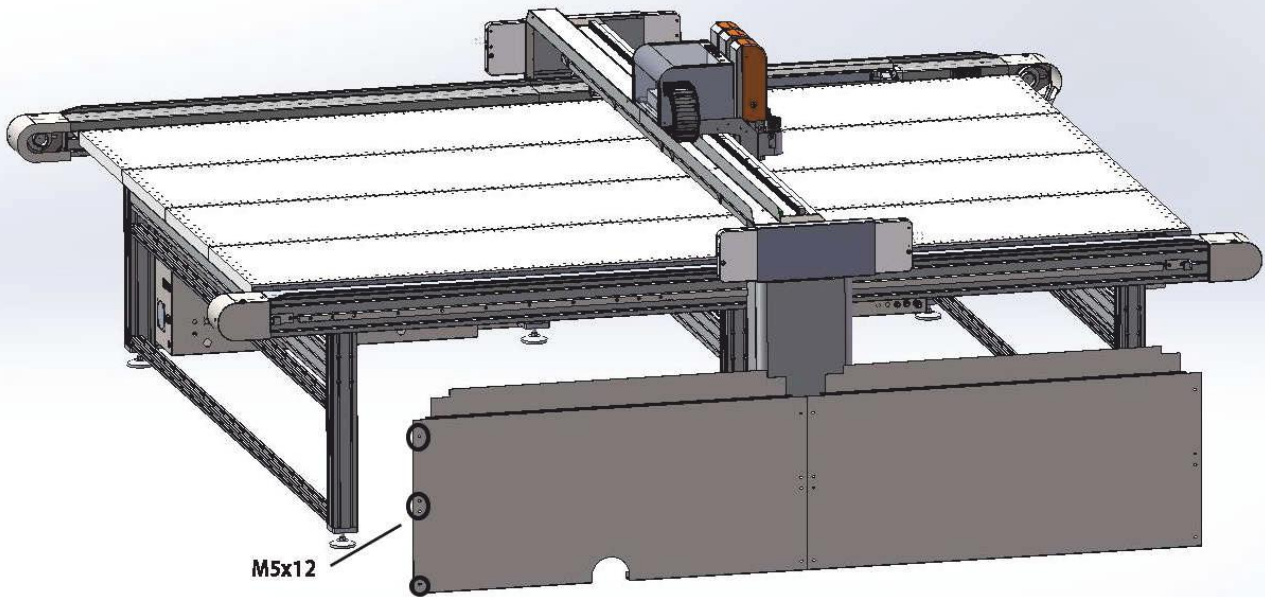
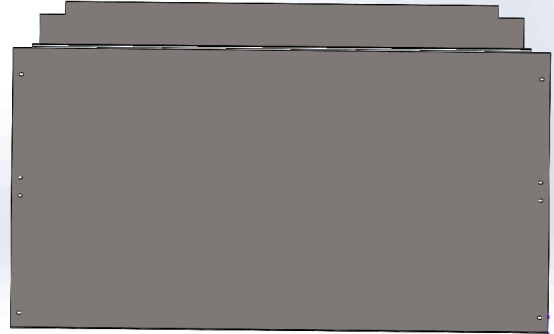
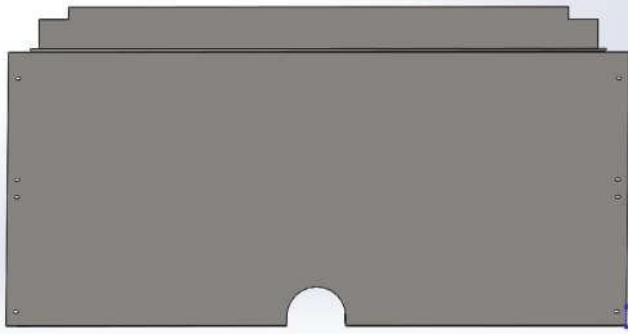

3.8 Pneumatic Control

1. Connect the double-color pipe on the regional air control box to the valves.

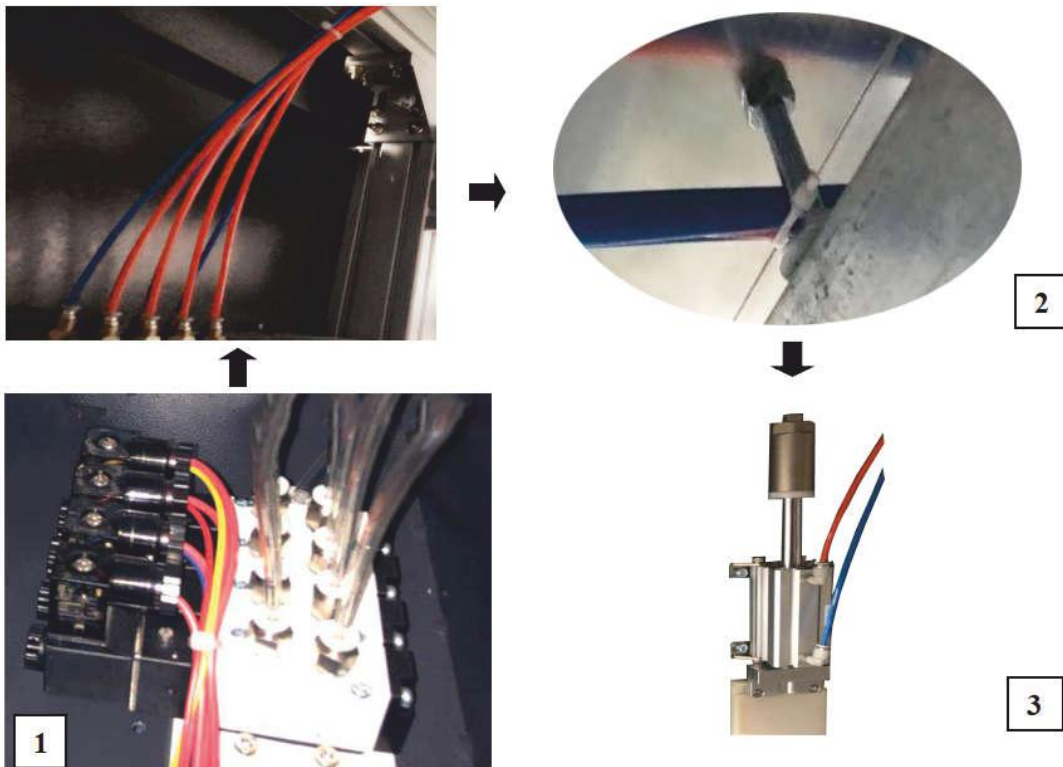

- 1 Pneumatic lines on the distributor
- 2 Cable tie point

- 3 Air Valve

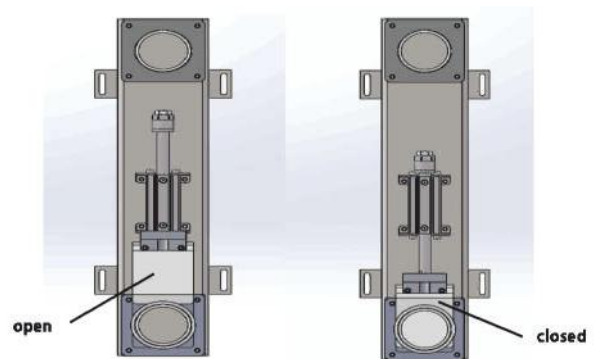

- A Pull the pneumatic lines from the distributor to the air valves .
- B Fasten the lines to the designated points using cable ties.
- C Connect the pneumatic lines in order on the air valves. The first cable in each group is numbered.

2. Connect the double-color pipe on the regional air control box to the valves (Advertising industry).

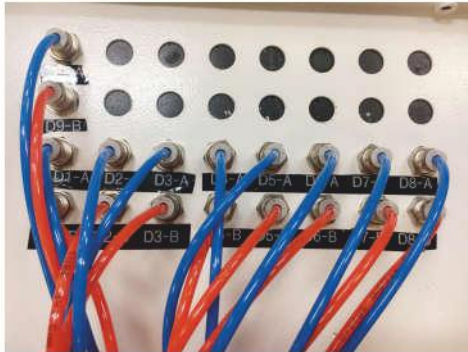

2

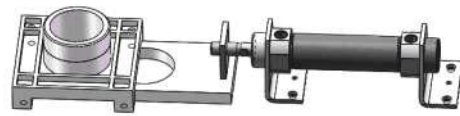
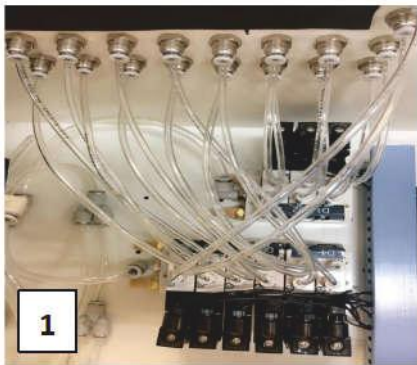

3

1 Air tube

3 Air Valve

2 Cable tie point

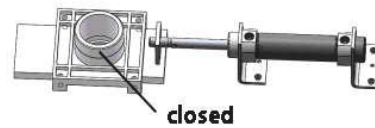
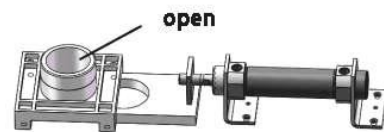

- A Connect the air tube in proper order on the air valves. The first cable in each group is numbered.
- B Fasten the lines to the designated points using cable ties.

3.9 Installing the Electric Box

Installing the electric box rail rack on the right middle leg of the equipment. Then put the electric box to inside.

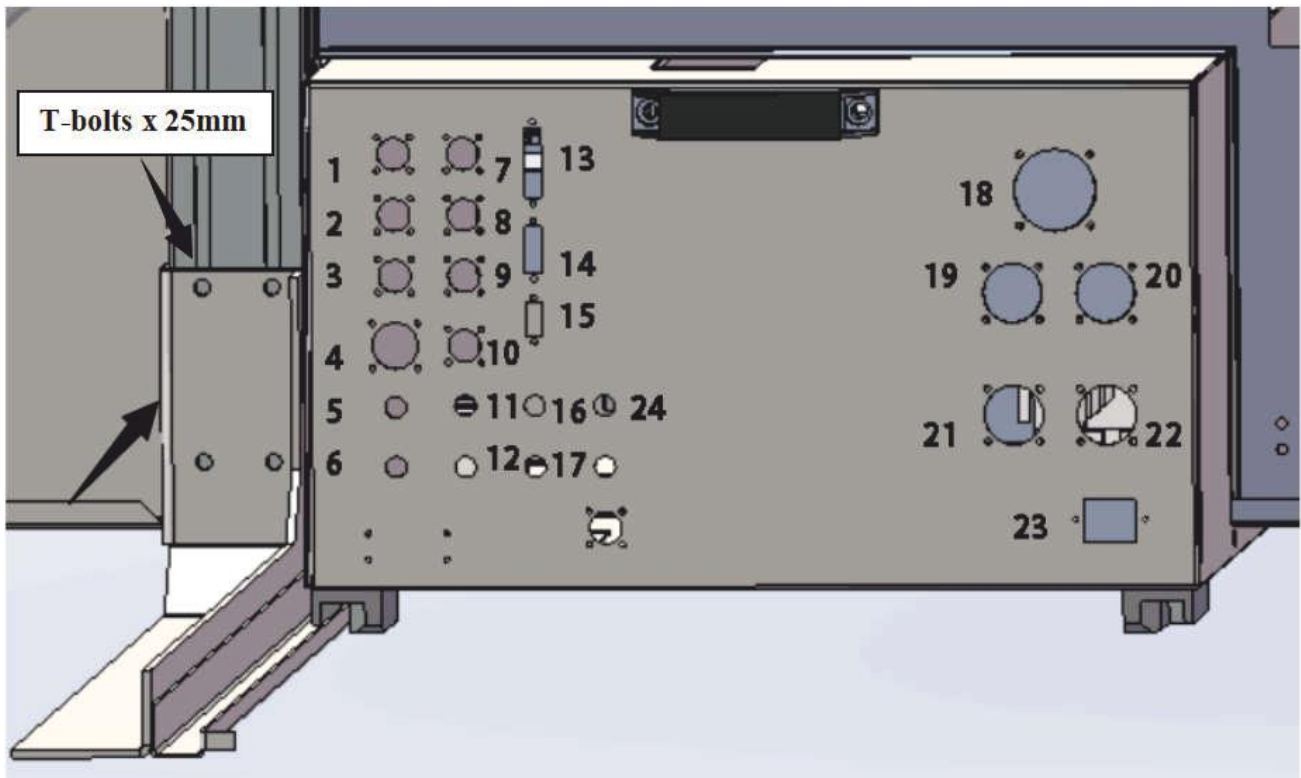

1	Bits holder CTRL	13	RZ CTRL
2	Solenoid valve CTRL	14	PC Comm
3	B board Power	15	Handheld Panel
4	B board COMM	16	1.5KW RZ
5	Gas Field CTRL	17	EMG Switch CTRL
6	Main / sec cut CTRL	18	X motor CTRL
7	Sensor CTRL	19	Head 1
8	Pump CTRL	20	Y motor CTRL
9	AKI 1 for zero position	21	Head 3
10	AKI 2 for the other side	22	head 2
11	SF CTRL	23	220v IN
12	EMG Stop CTRL	24	Cleaner CTRL

3.10 Assemble main cable etc.

Assemble main cables and towing chain parts on the side of X axis of zero point. The PVC pipes are labeled, the order must be followed and then put the cover. The other side is connecting the electric box.

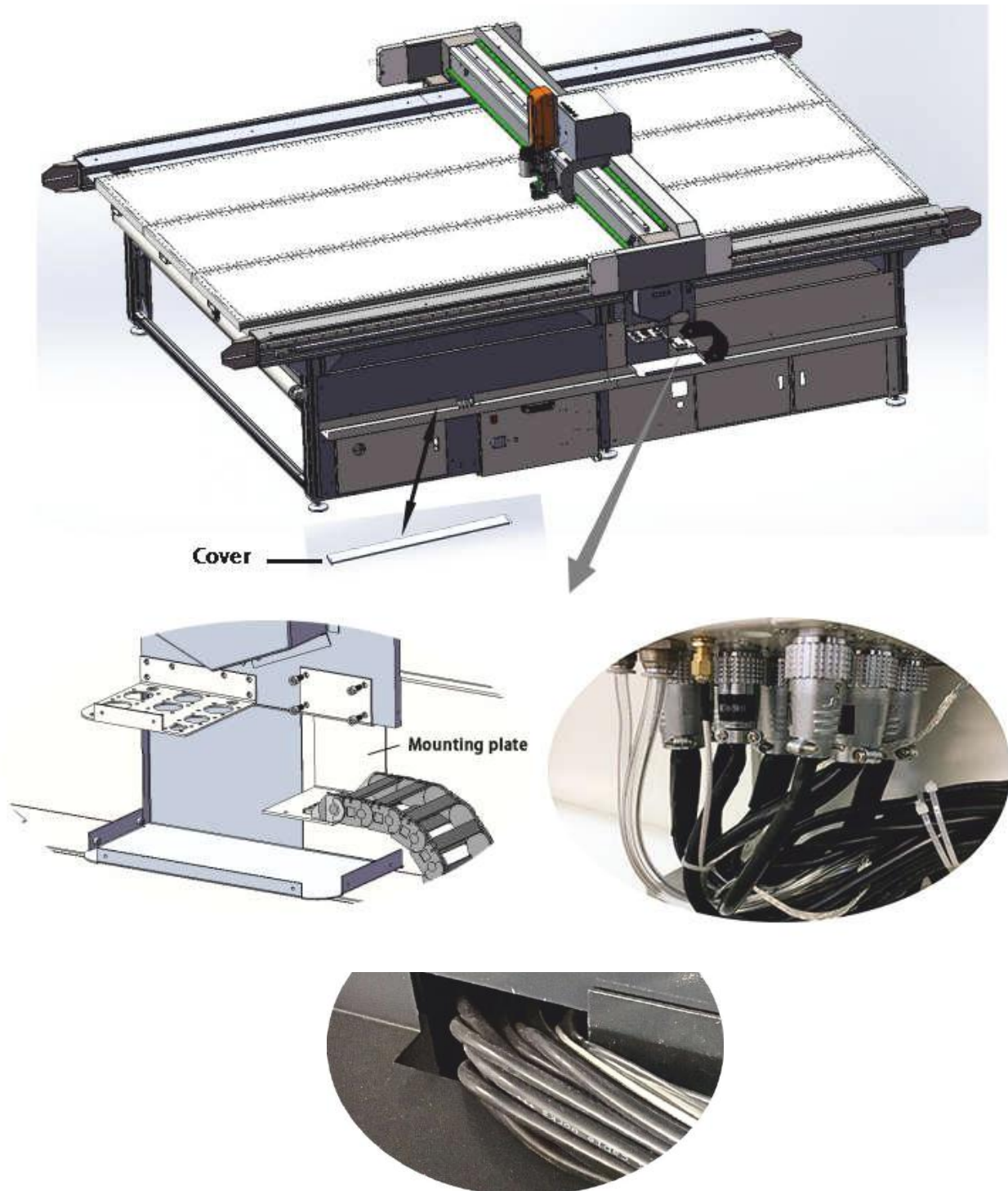

3.11 Install the Conveyor Belt Guide Rollers Device.



Tip:

Observe the following differences between the front and rear of conveyor belt guide rollers during installation.

- The front guide roller are equipped with pulley of auxiliary motor.
- The rear guide rollers are equipped with guide rings.

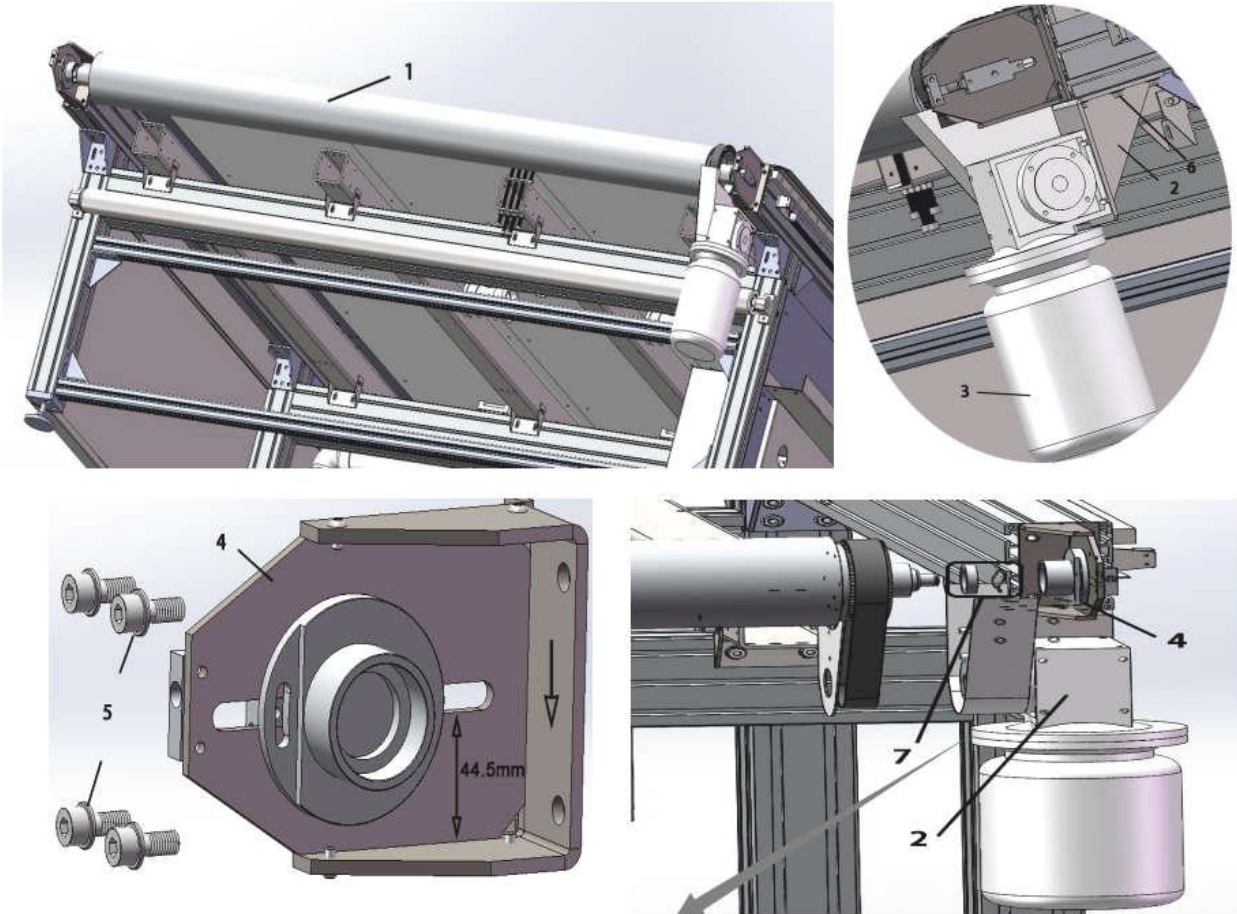

Installing steps of this parts : 1. motor bracket support(2) 2. mounting plate(4)

- | | | | |
|---|----------------------------|---|--------------------|
| 1 | Conveyor belt guide roller | 5 | 4 x Screws (M8x16) |
| 2 | Motor bracket support | 6 | 6 x Screws (M5x16) |
| 3 | auxiliary motor component | 7 | 2 x washer |
| 4 | Mounting plate | | |

A Attach the slots on the conveyor bracket using the screws.

B Tighten the screws.

C Repeat the procedure on the other side.

Note: auxiliary motor cable to connect the frequency converter box.

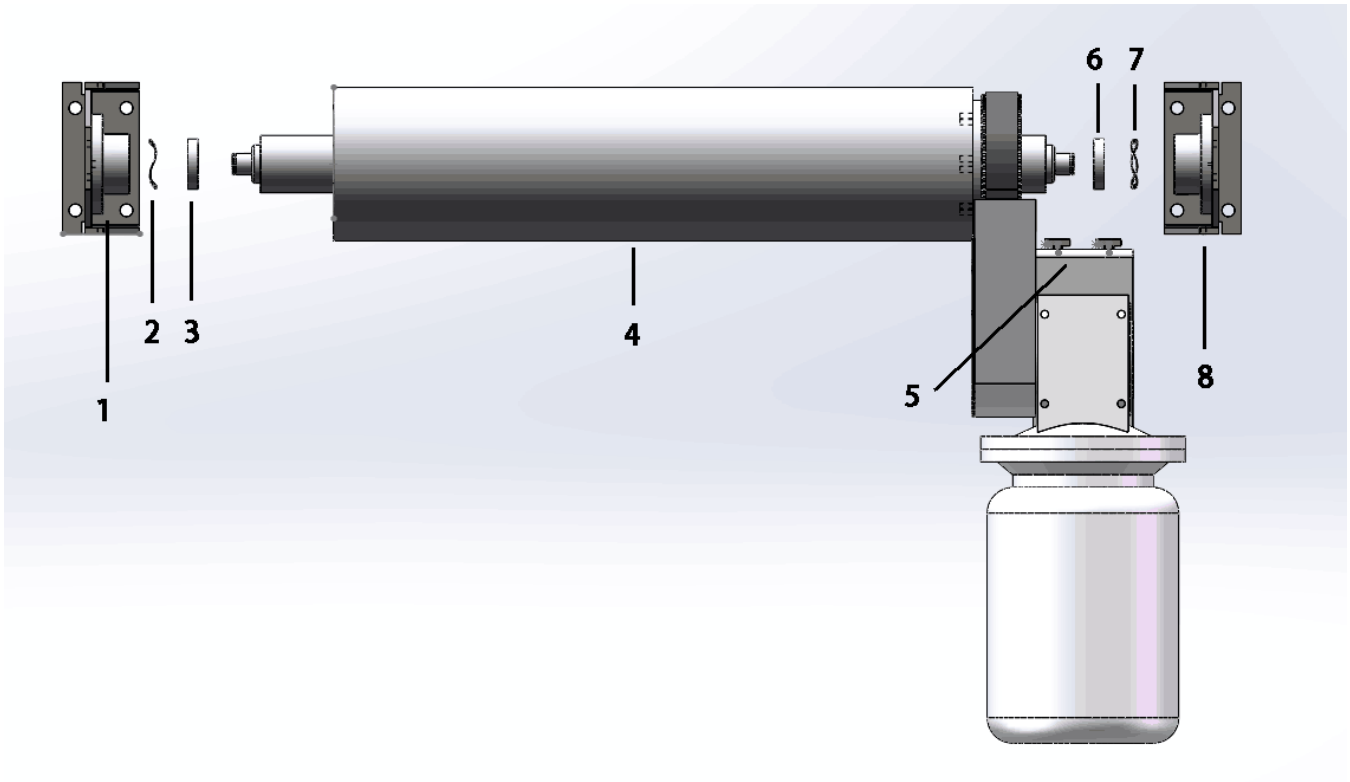

Installing steps of the front : 1 - 2 - 3 - 4 - 5 - 6 - 7 - 8

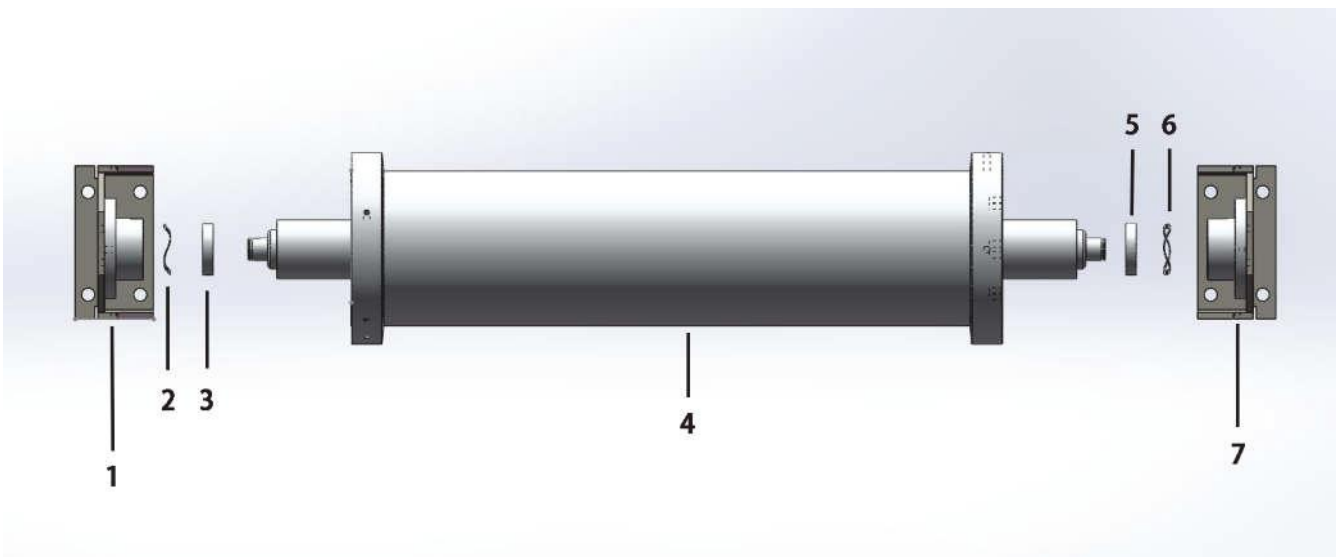

Installing steps of the rear side : 1 - 2 - 3 - 4 - 5 - 6 - 7

Install roller panel component on each side of the machine and pause button.

Pause cable to connect the position of number 1 from electromagnetic valve controller of electric box.

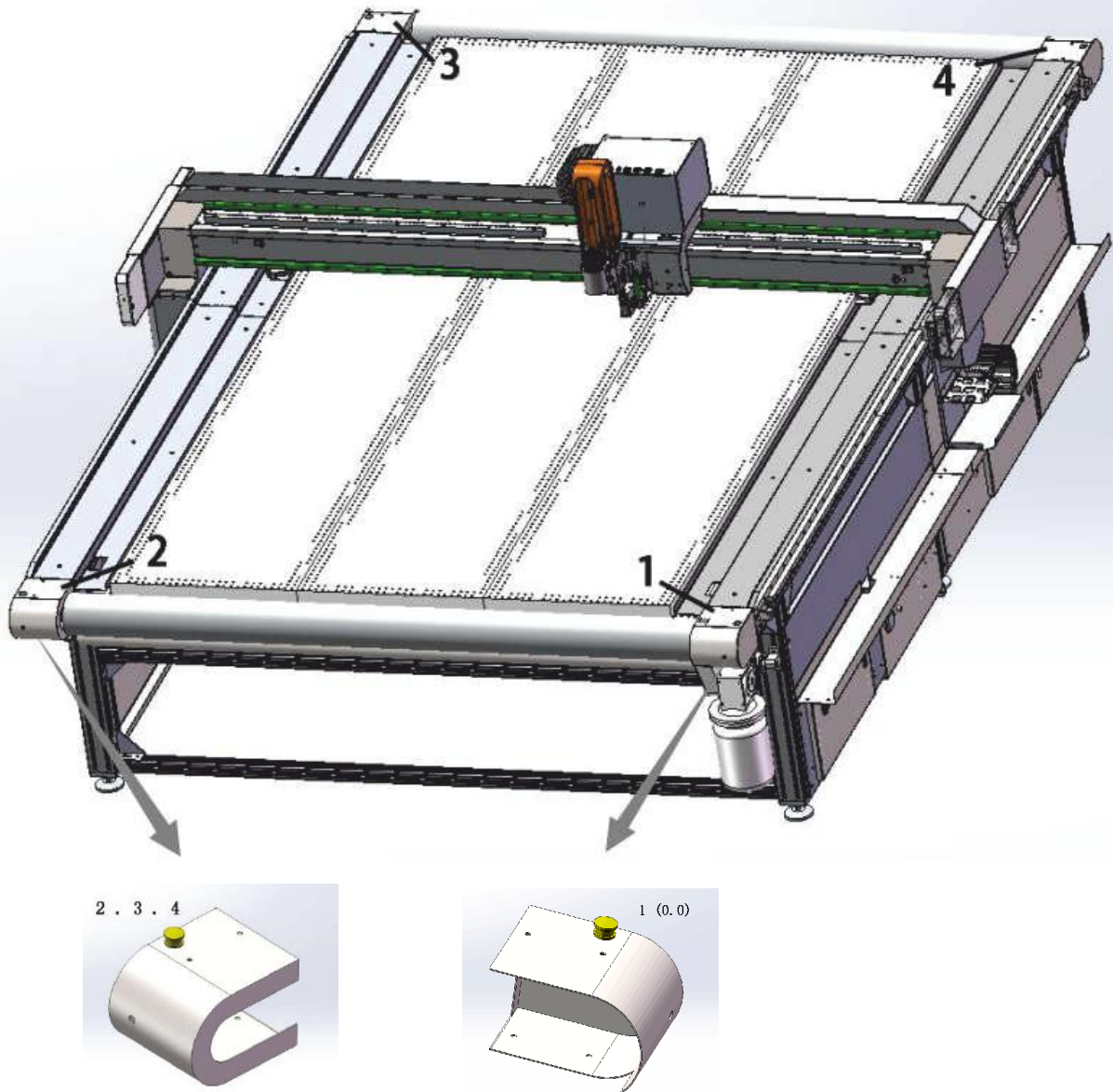

3.12 Install the AKI Device.

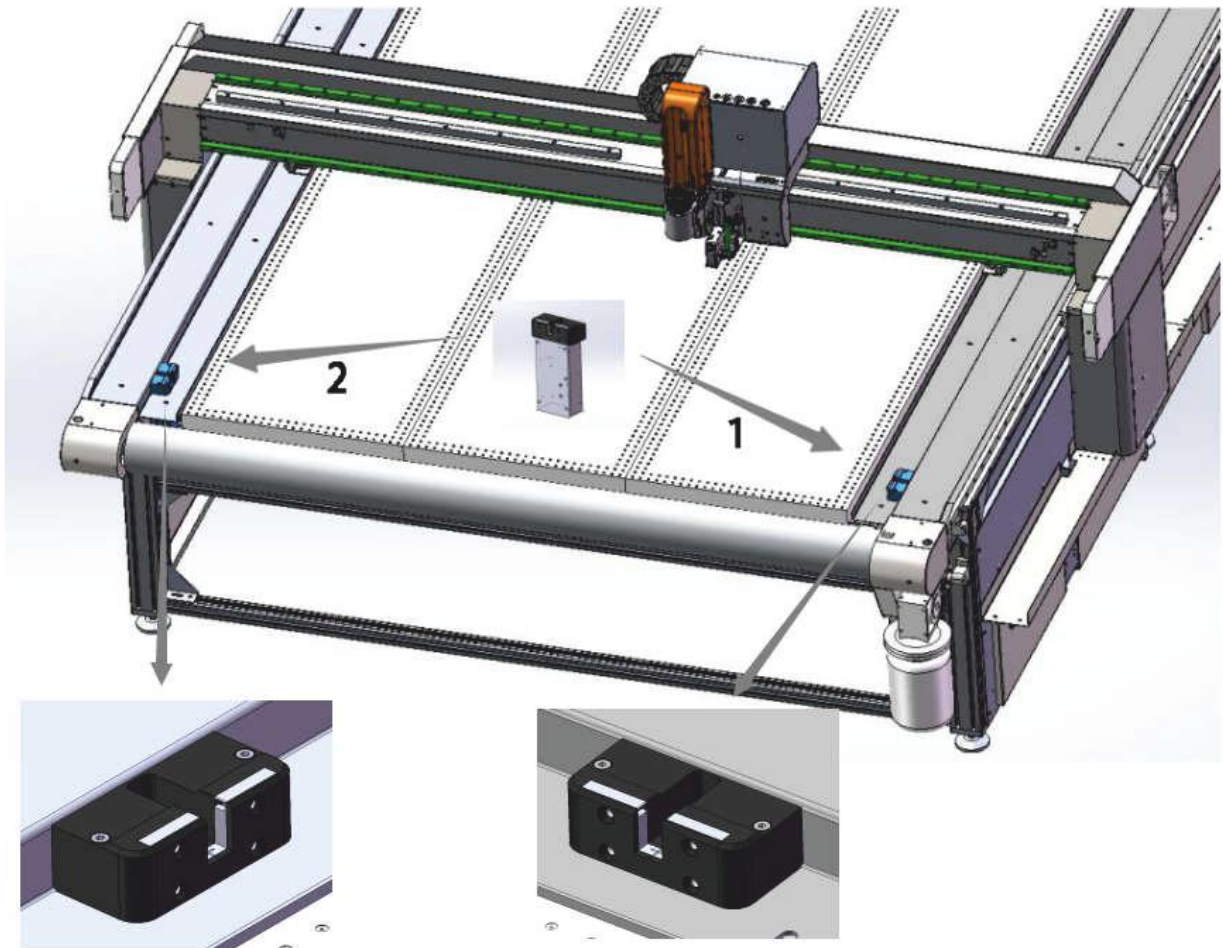

- A** Tighten both screws (M4 x40)
- B** AKI 1 to connect electric box with short one cable.
- C** AKI 2 to connect electric box with longer one cable.

3.13 Other Cables Function of Instructions

3.13.1 The frequency converter box

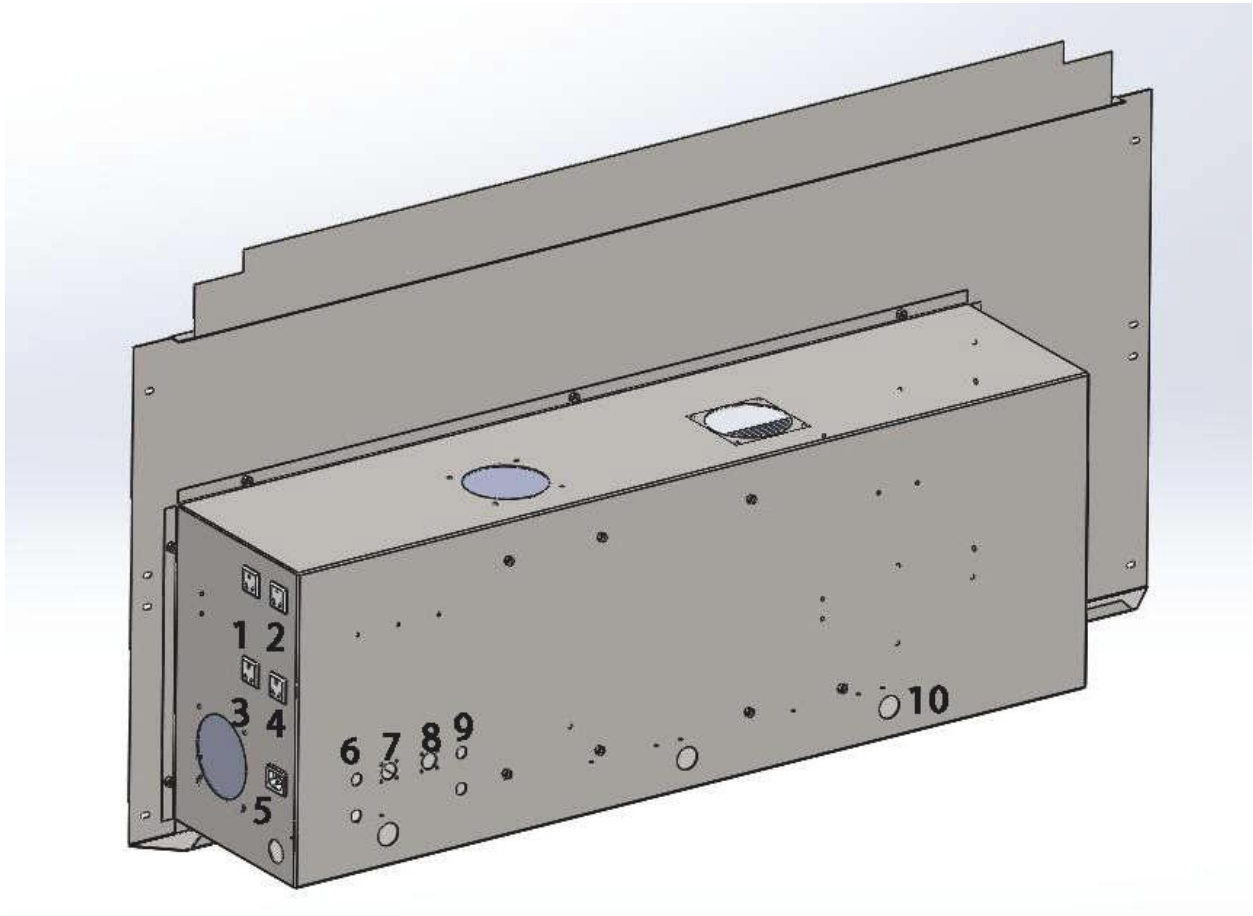

1	AC220V OUT	6	Pump CTRL EXT
2	Cleaner Power Supply	7	Pump CTRL
3	AC220V OUT	8	AUX. Motor CTRL
4	AC220V OUT	9	Main Power CTRL
5	AC220V IN	10	Pump Power IN

- A** AC220V OUT (3) to connect the main electric box
- B** AC220V OUT (4) to connect the regional air control box
- C** Pump CTRL to connect the main electric box.
- D** Main Power CTRL to connect the PC table

3.13.2 The regional air control box

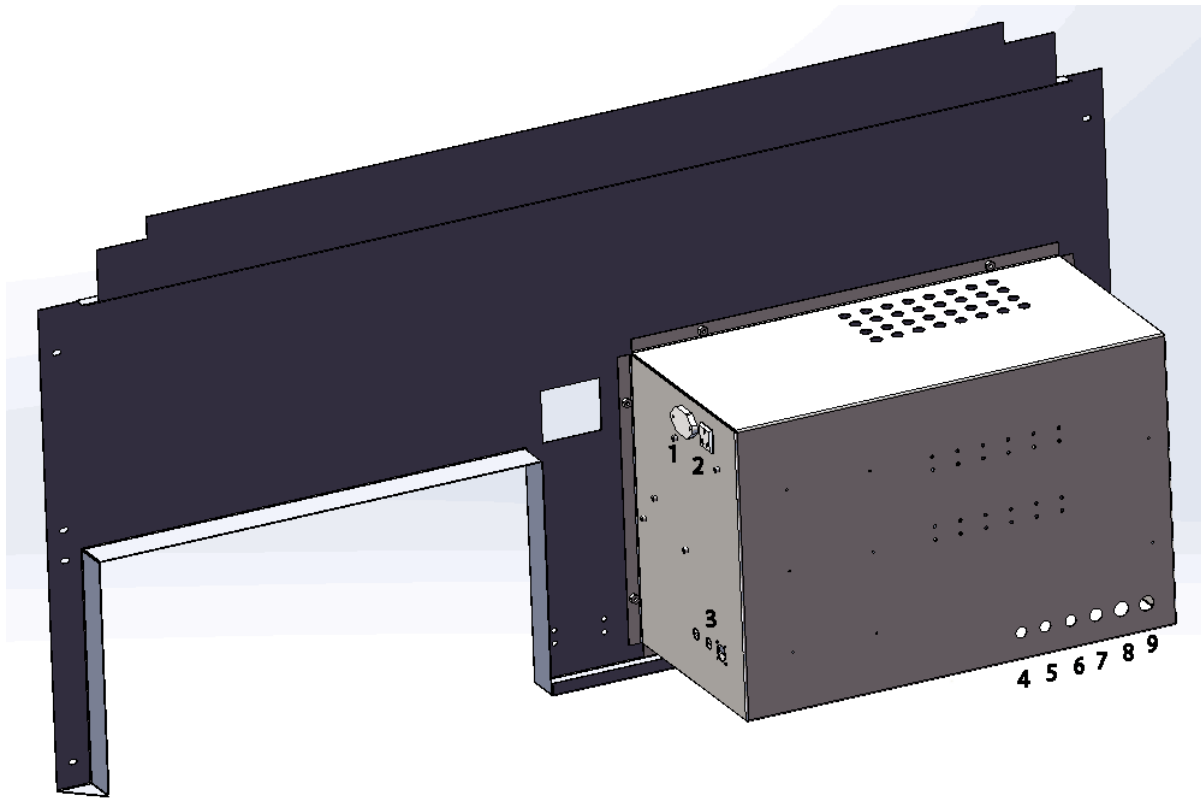

1	AC220V IN	6	Connector of milling tool
2	AC220V OUT	7	Connector of module
3	Gas Field CTRL	8	Connector of sheet device
4	Connector of POT Tool	9	Connector of main air input of $\Phi 8\text{mm}$
5	Connector of changeover device		

A AC220V output (2) to connect the plug of PC table

B The Gas Field CTRL to connect the main electric box

3.14 Assemble the Workstation

3.14.1 Connect the monitor, keyboard and mouse

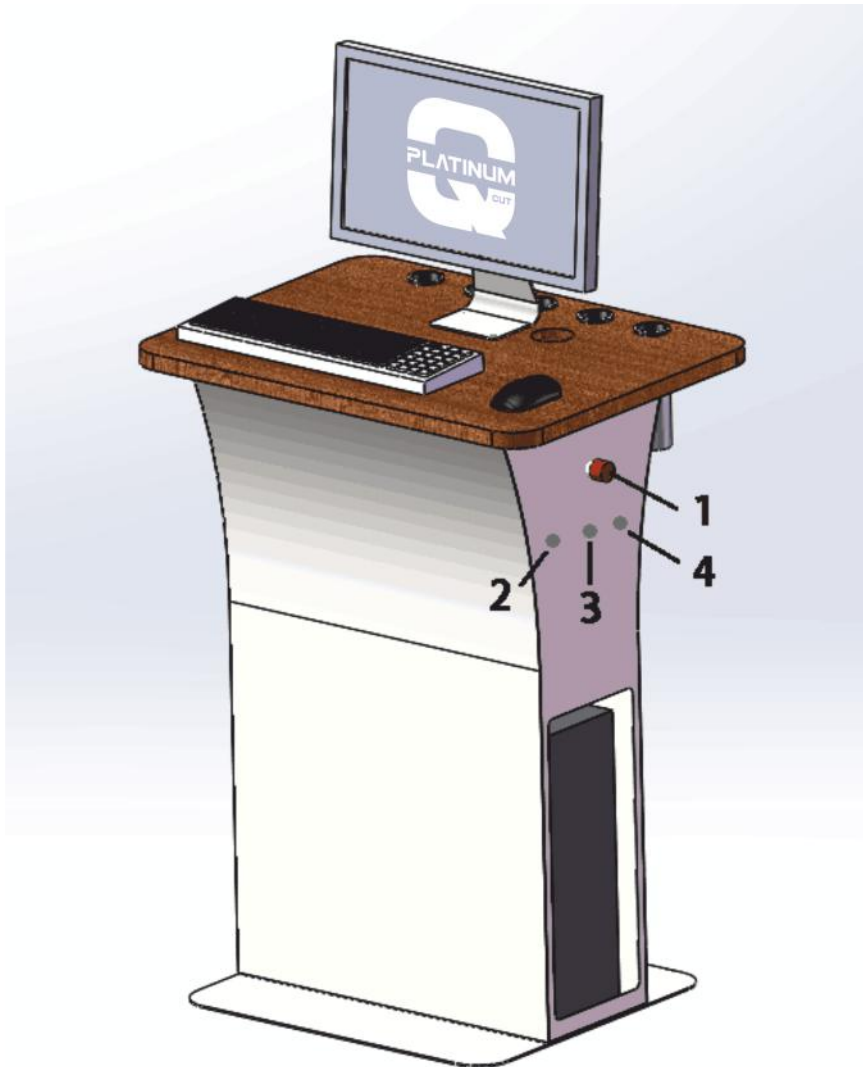

- | | | | |
|---|----------------|---|---------------------------|
| 1 | Emergency Stop | 3 | Auto / Manual for Cleaner |
| 2 | START | 4 | STOP |

- A Install the monitor, keyboard and mouse cable as shown.
- B Secure the cable with cable ties.
- C Emergency stop cable to connect emergency switch CTRL of electric box.

3.14.2 Connect the PC to the cutter

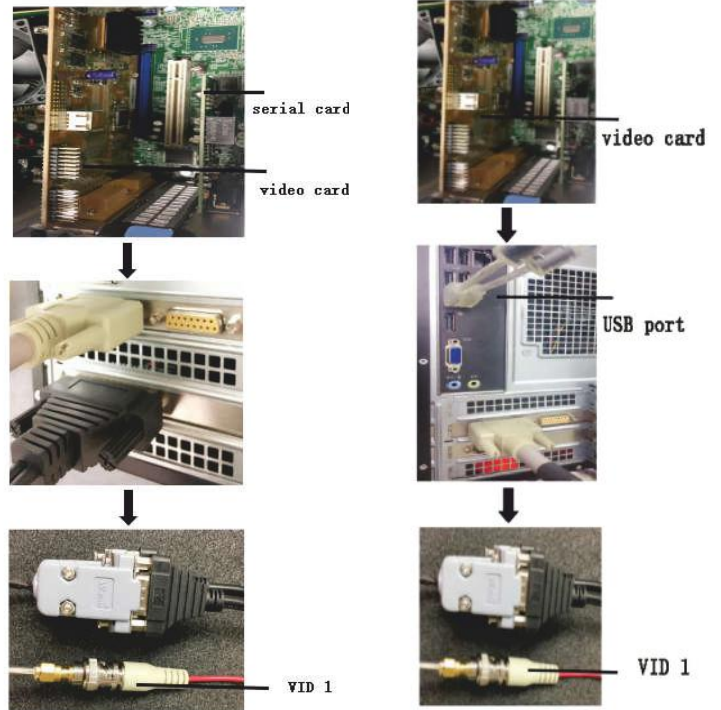
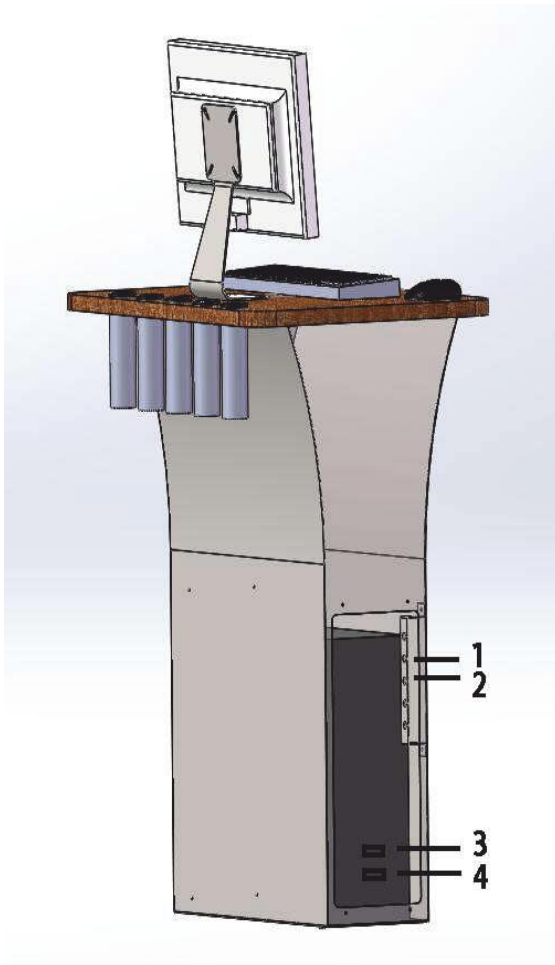

- 1 Cleaner CTRL
- 2 Main Power CTRL

- 3 Serial card / USB-890k
- 4 Video Card

- A** Cleaner CTRL (Q-Cut63P) to connect the electric box
- B** Main Power CTRL (Q-Cut62P) to connect the rear side of frequency converter box.
- C** PC Communication cable to connect the serial card.
- D** VID 1 to connect video card

3.15 Install the Conveyor Belt.







Warning:

Toxic fumes

Damages respiratory organs, skin, and mucous membrane of the eyes.

Only work in well ventilated rooms. Avoid contact with the skin and mucous membrane of the eyes. Wear protective gloves. Observe manufacturer's specifications

Tools and materials

	Adhesive tape
	Glue
	Cutter
	Screwdriver
	Felt mat

3.16 Tension the Conveyor Belt

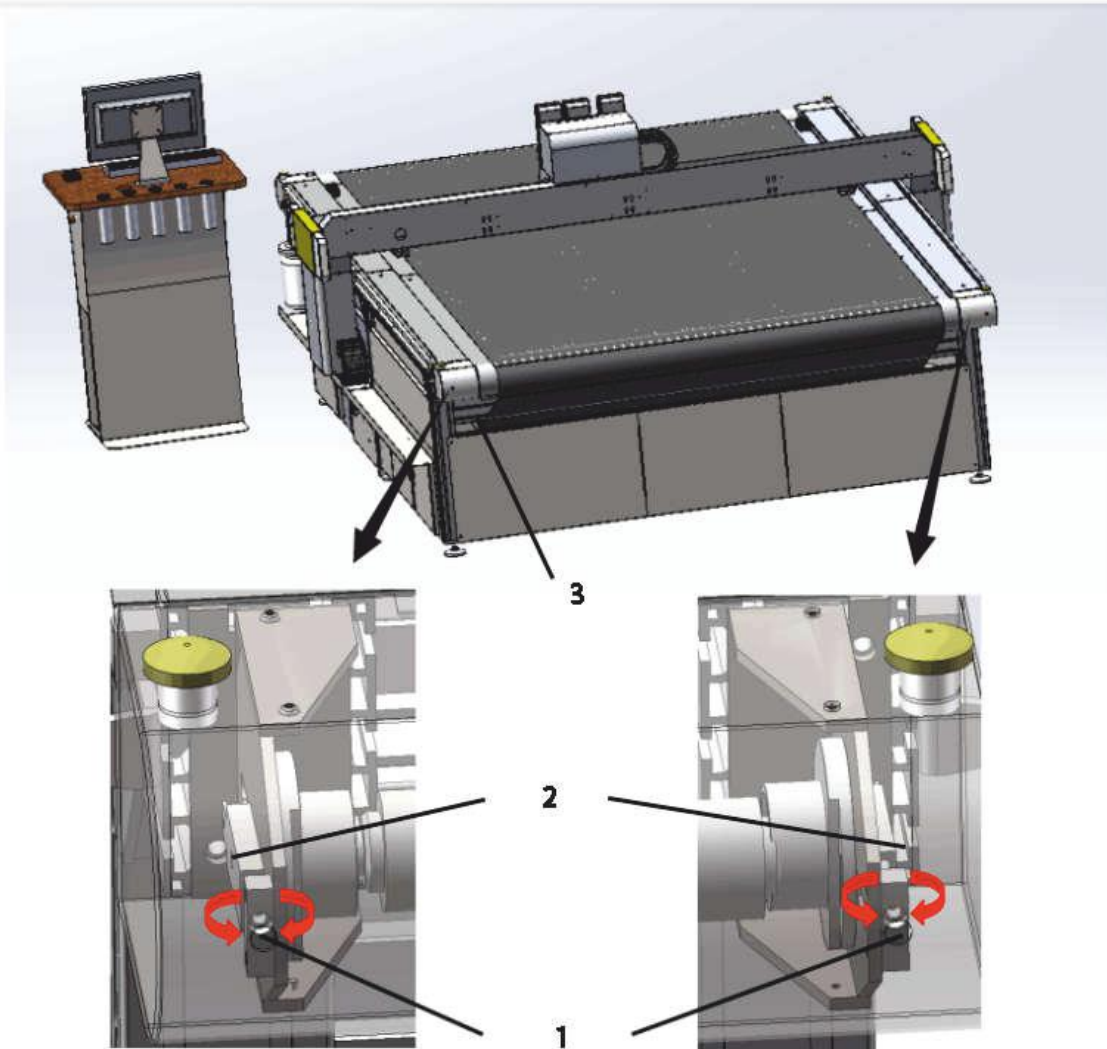

1 - 2 Adjusting screws (both sides)

3 Lower guide rollers (front and rear side)

- A** Tighten both screws evenly or lower guide rollers
- B** Check the conveyor belt tension.
- C** Manually move the conveyor belt by one turn.
- D** Check the conveyor belt tension again.

3.16 Tension the Conveyor Belt

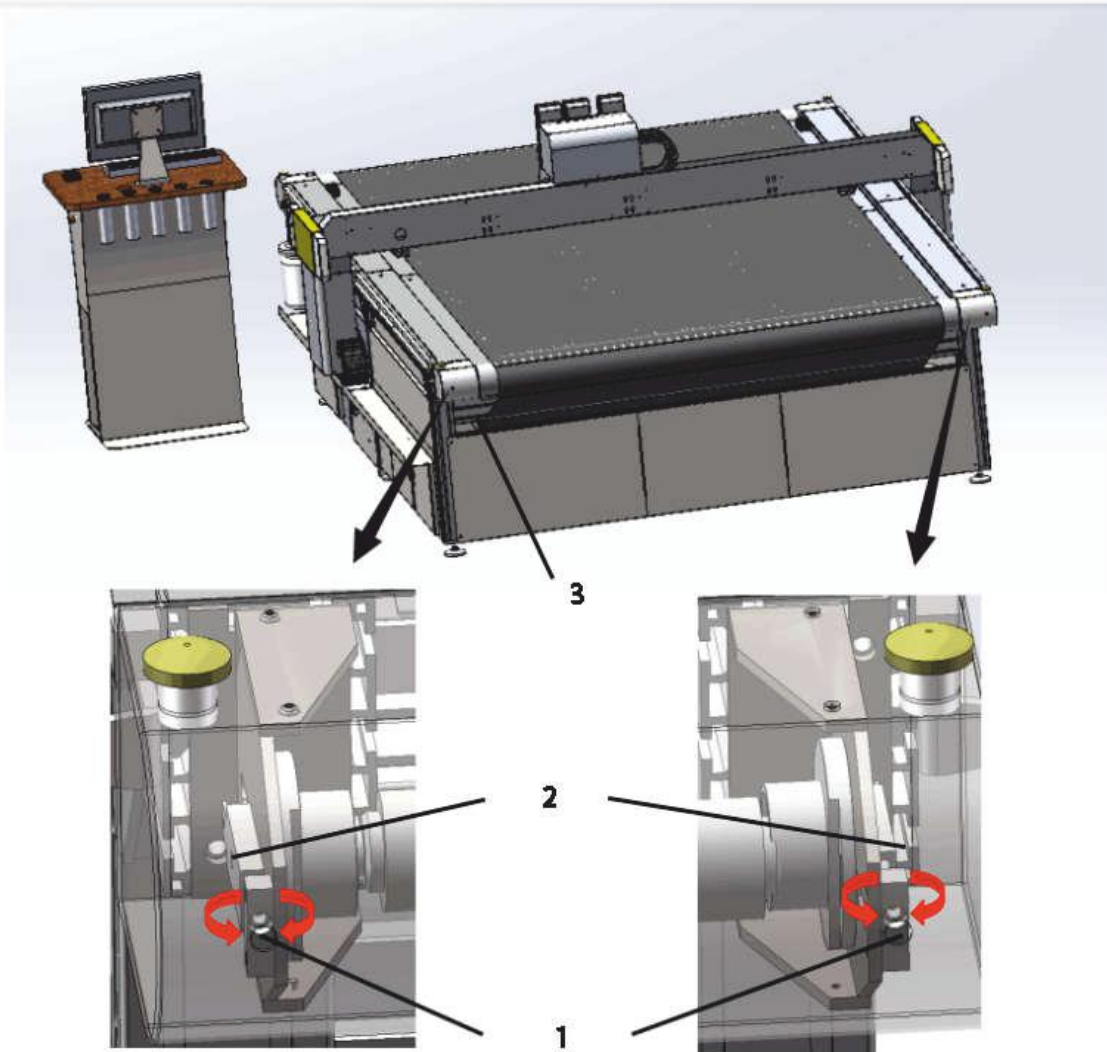

1 - 2 Adjusting screws (both sides)

3 Lower guide rollers (front and rear side)

- A** Tighten both screws evenly or lower guide rollers
- B** Check the conveyor belt tension.
- C** Manually move the conveyor belt by one turn.
- D** Check the conveyor belt tension again.

3.17 Assemble the Milling Support Device.

3.17.1 Regular the Milling support device. (The total height: 2.8 m)

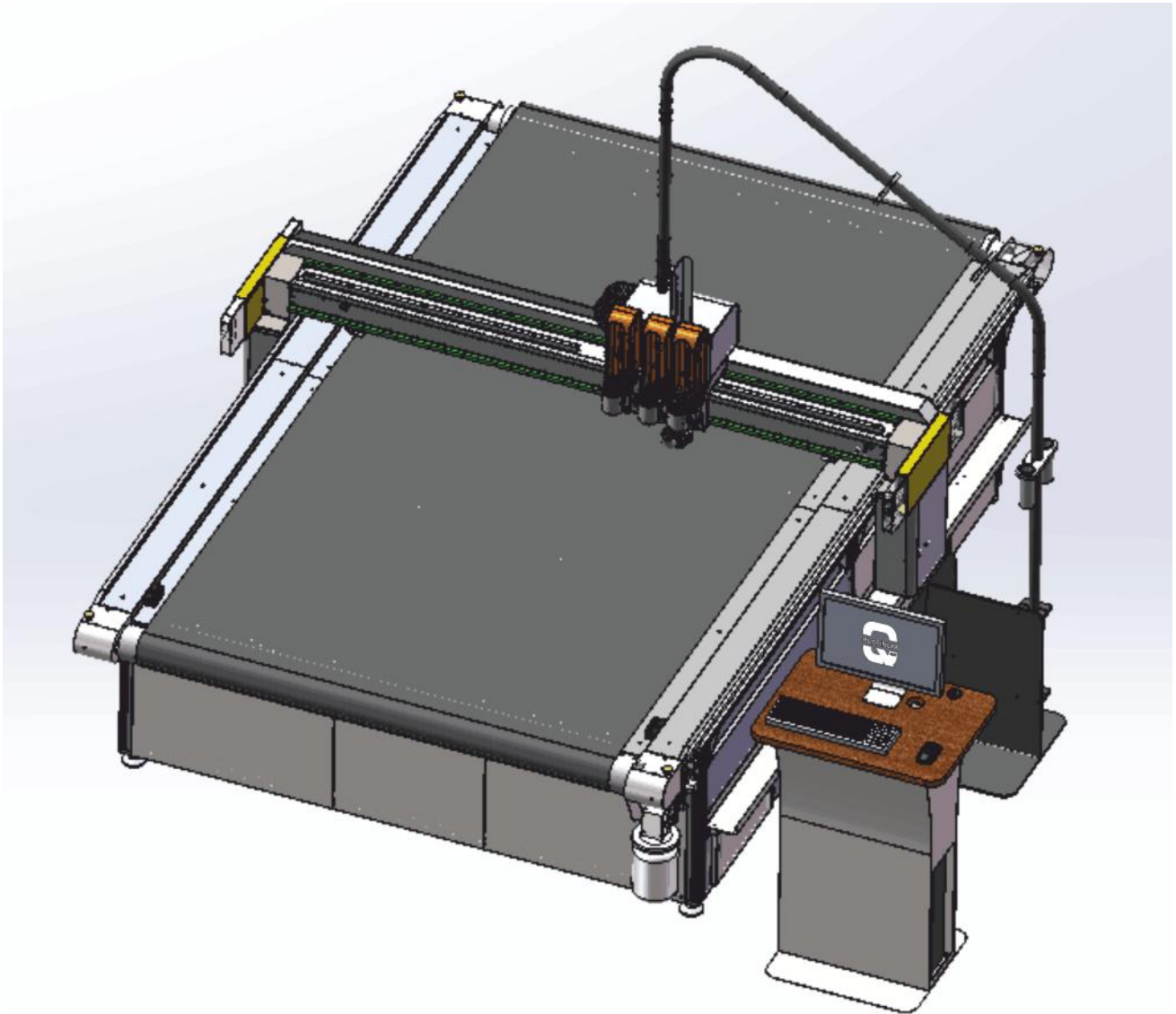

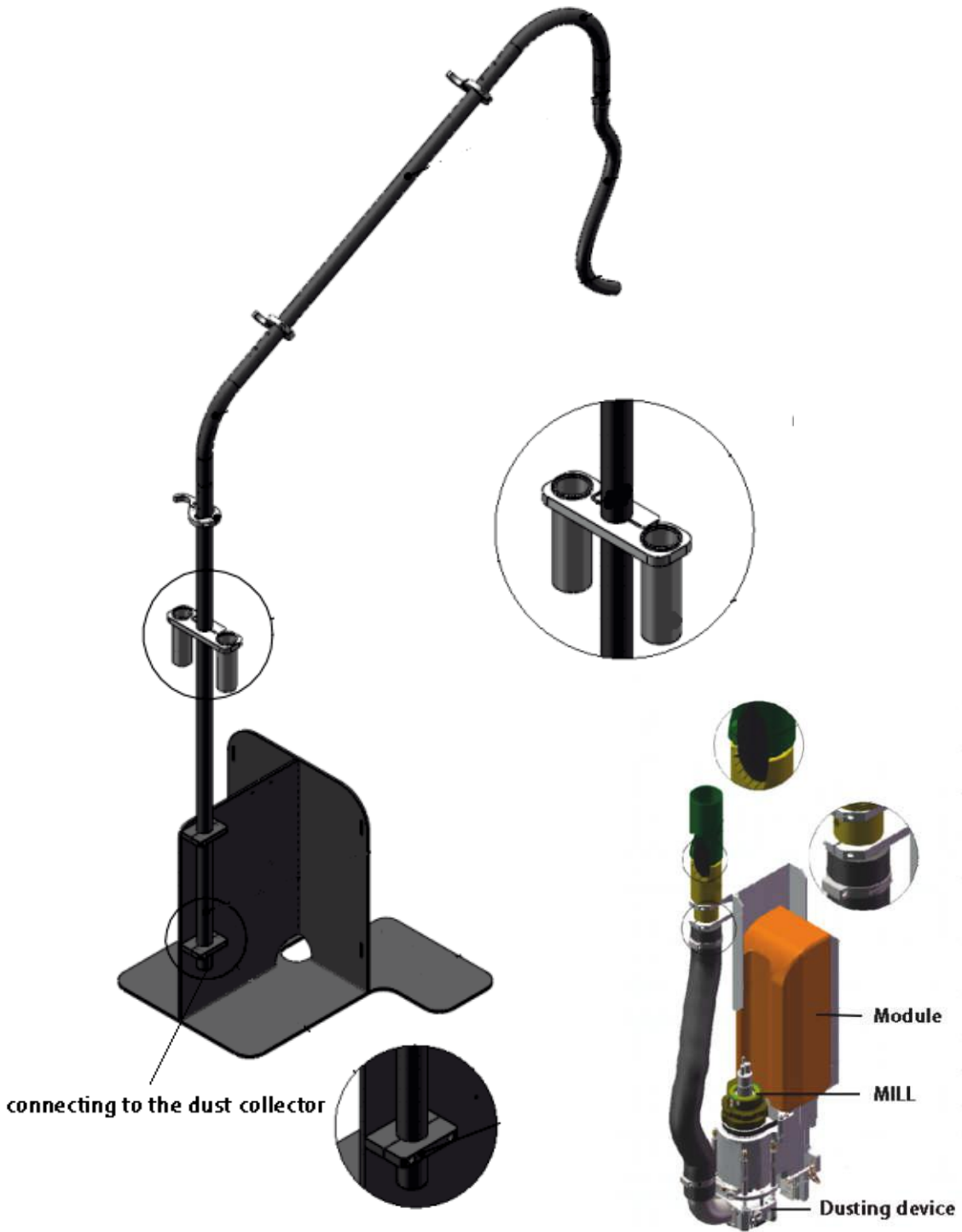

Connect cables in the milling device support

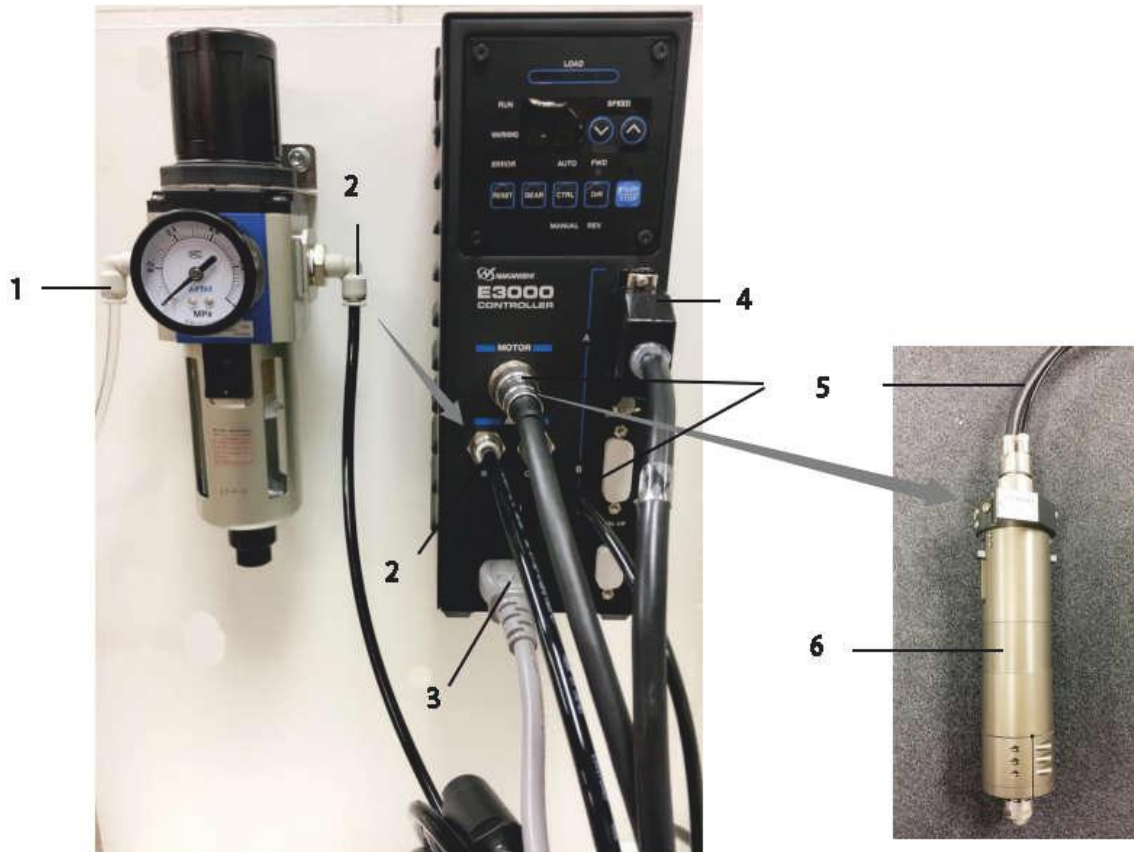

- | | | | |
|---|---------------------------------|---|---|
| 1 | Air input of $\Phi 6\text{mm}$ | 4 | Milling tool communication cable |
| 2 | Air output of $\Phi 6\text{mm}$ | 5 | Milling tool power and $\Phi 4\text{mm}$ tube cable |
| 3 | AC 220V Power input | 6 | Milling tool |

3.17.2 Large table milling support device (The total height : 2.8 m)

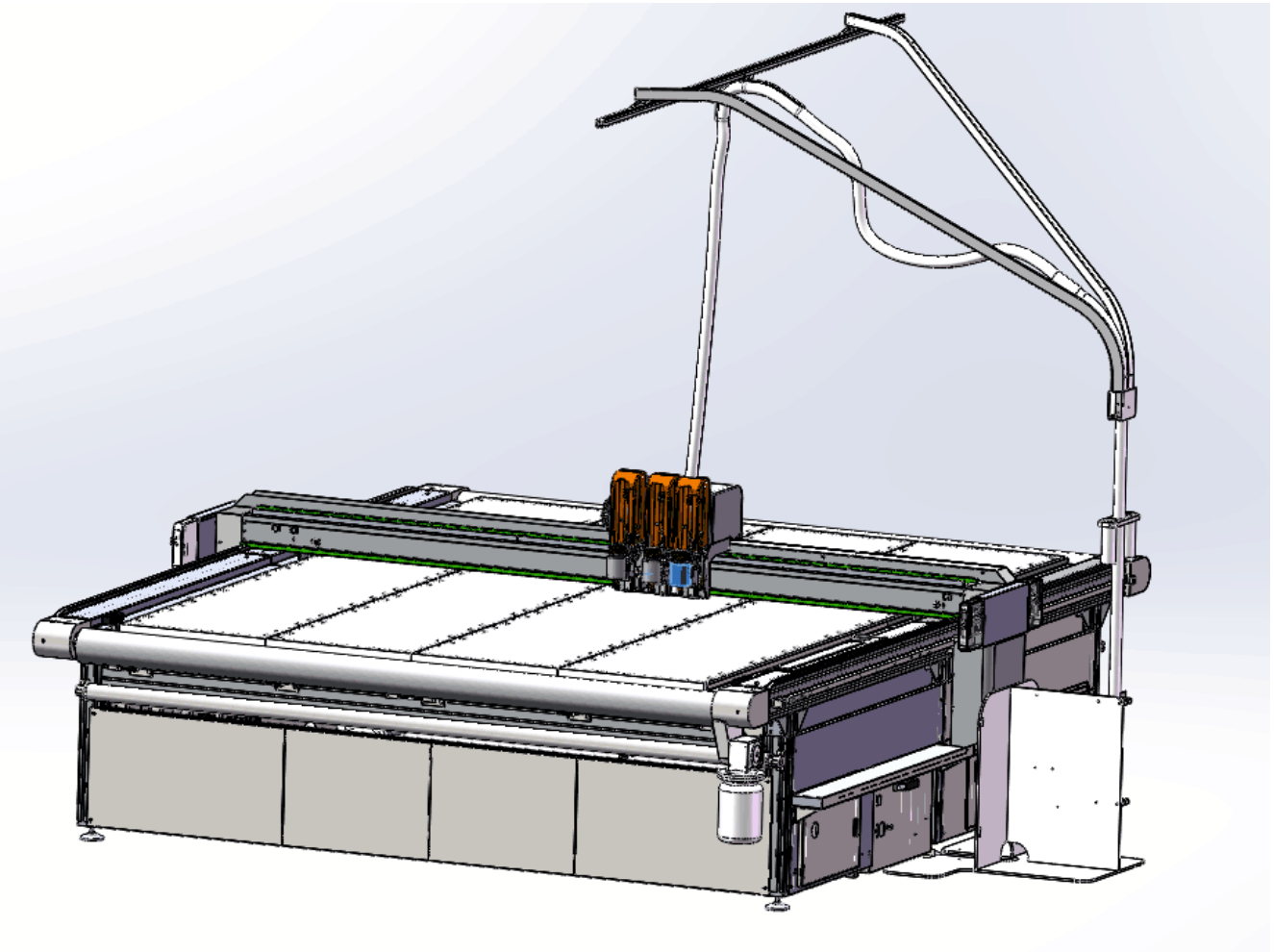

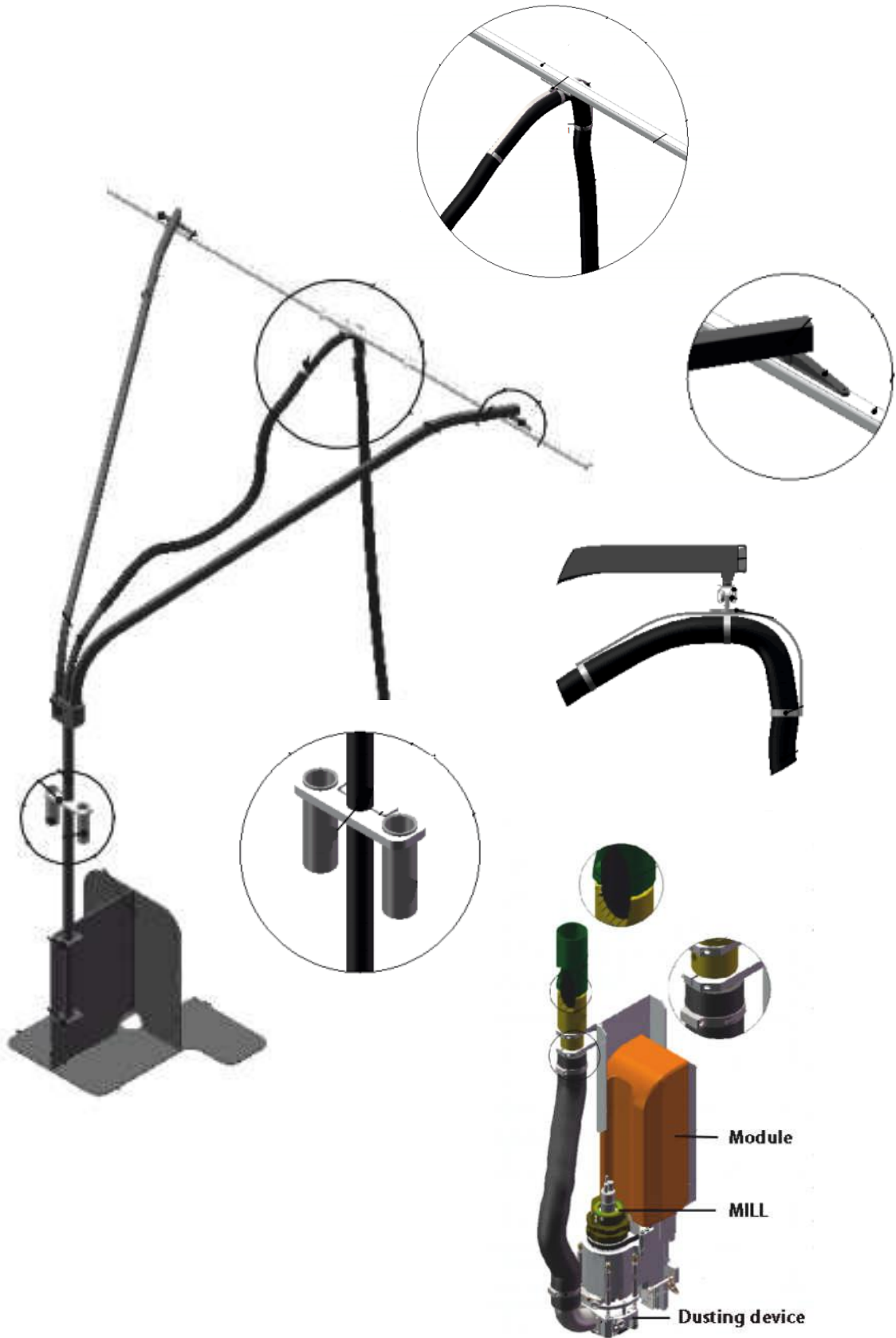

3.18 Install the Covers of The Front and Rear Side.

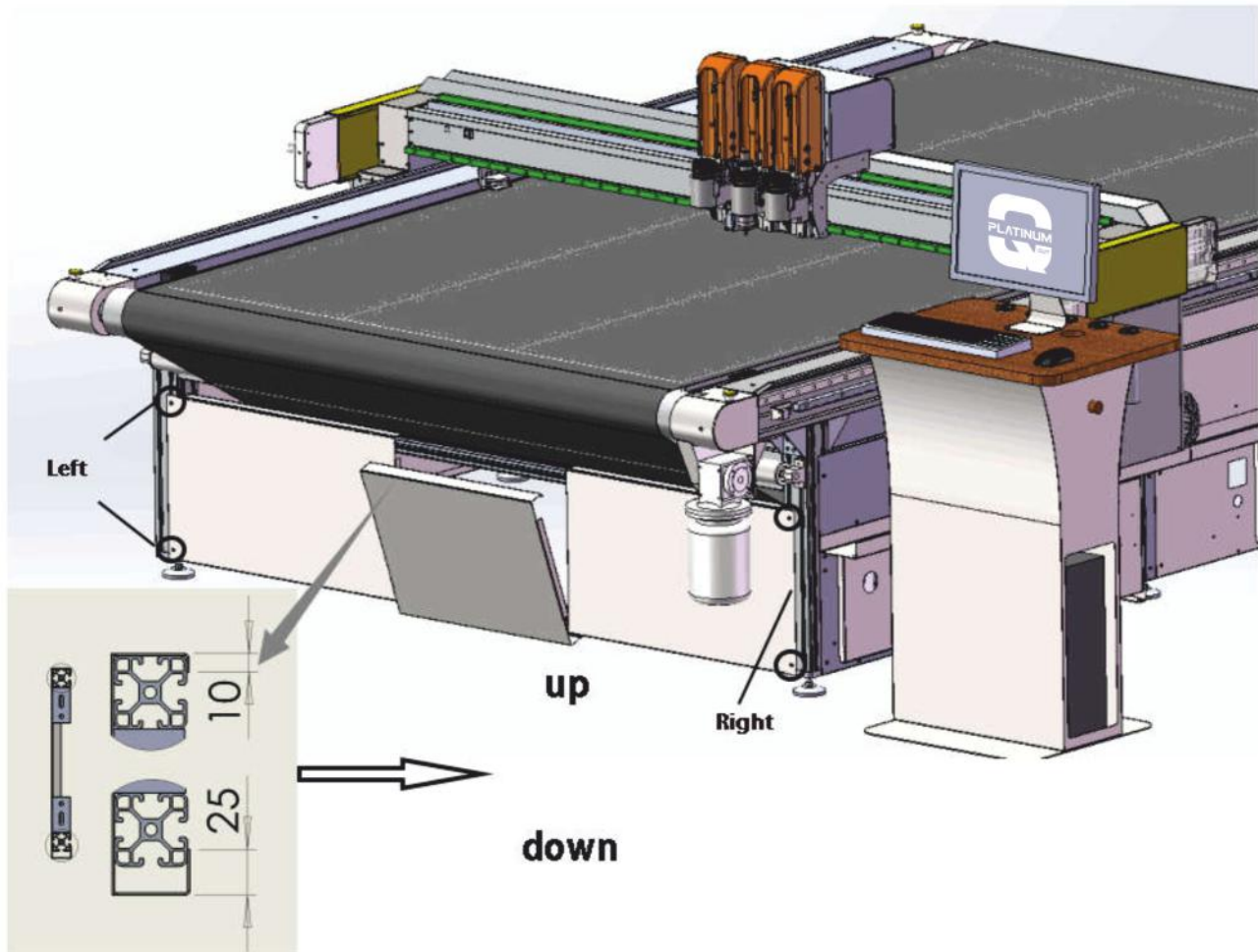

3.19 Circuit Boards

■ Boards Positions In Electrical Box

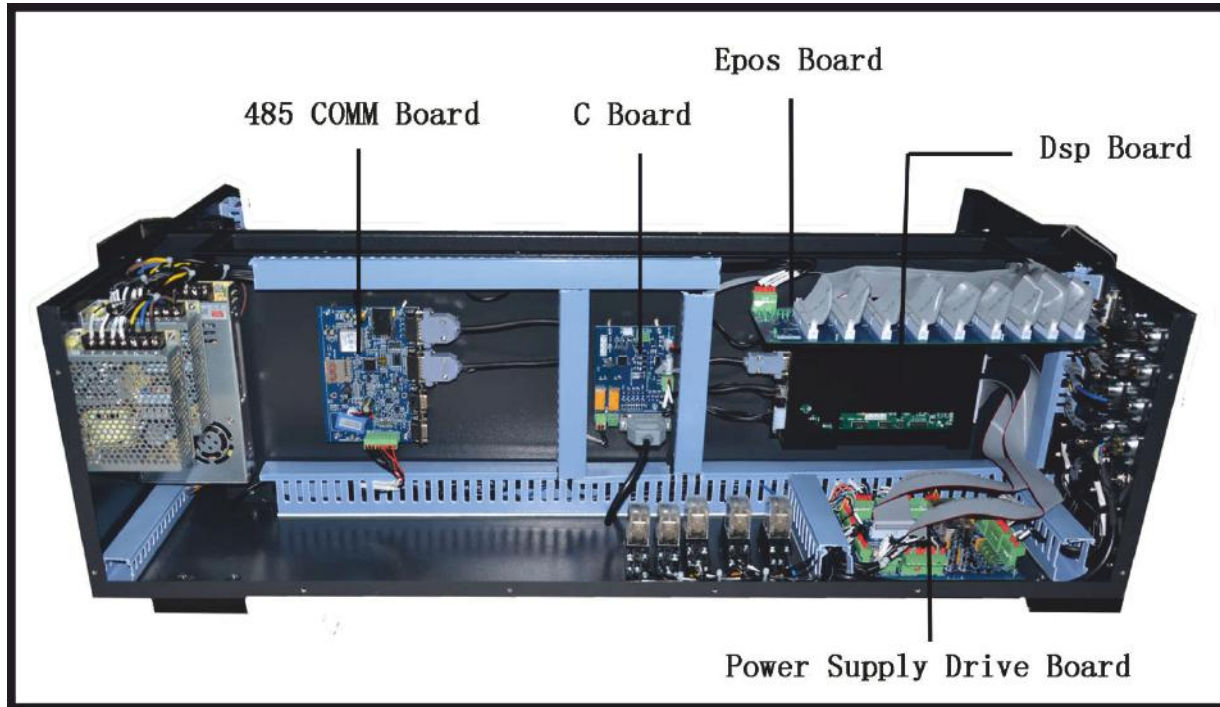

■ Boards positions on machine (behind the cutting head device)



4. Danger Areas During Initialization

4.1 Danger Area On the Module Carriage

Caution:



Risk of injury on the module carriage!

The danger area on the module carriage is not secured by safety devices.

- Do not reach into the danger area during manual initialization.
- Secure the danger area on the module carriage with protective slot plates.

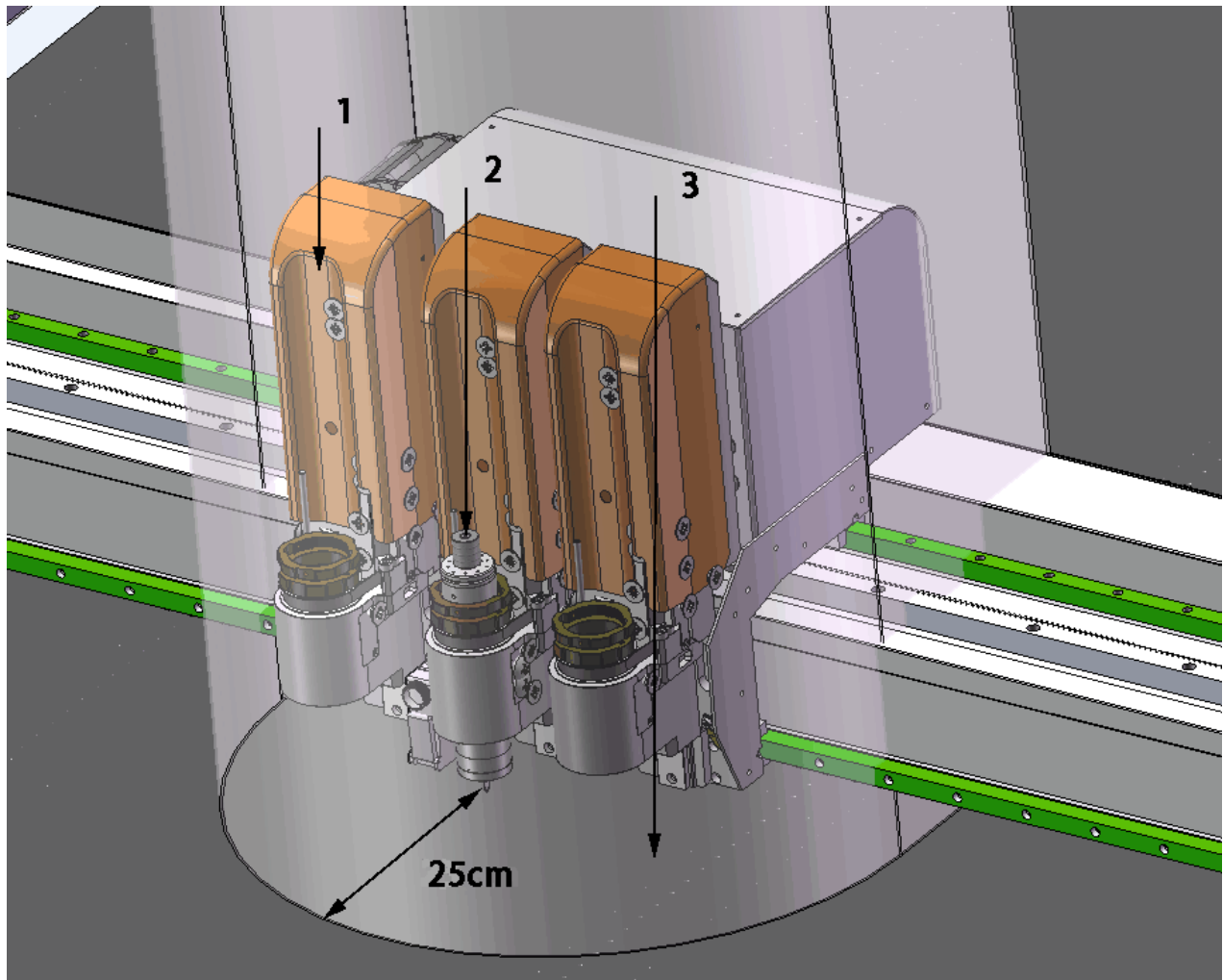

- 1 Module
- 2 Tool (UCT)
- 3 Danger area

(Safety distance during initialization is 25 cm)

4.2 Safety Device On the Machine and PC Table.

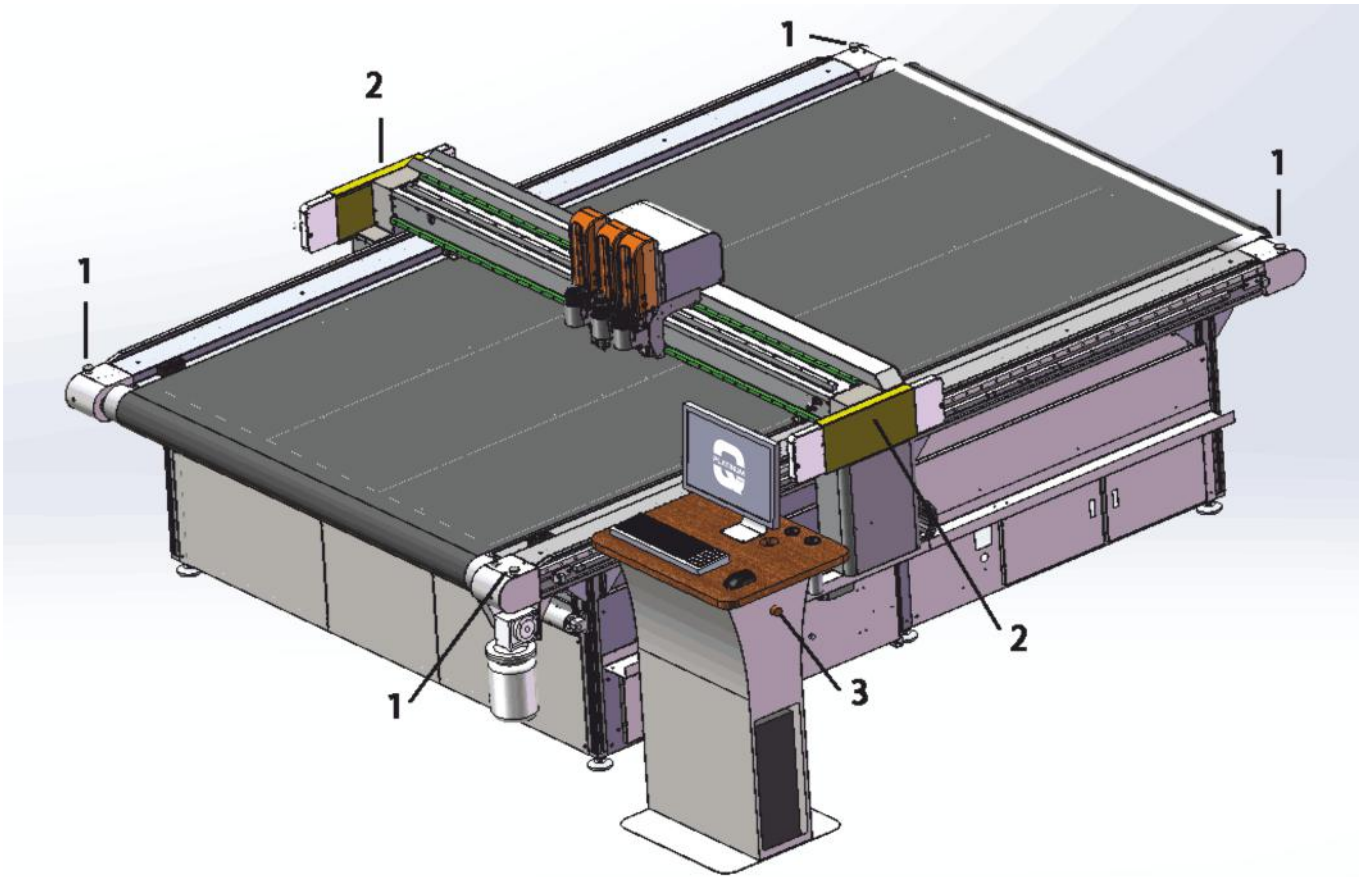

- 1 Pause Switch
- 2 Protective System

- 3 Emergency Stop Switch

5. Power and Air Supply Connecting

Users should supply two cables and $\Phi 8\text{mm}$ air tube.

1. Vacuum pump: three-phase four-wire electronic control system, plug in the power with five-wire
2. Machine and PC : single-phase three-wire electronic control system .

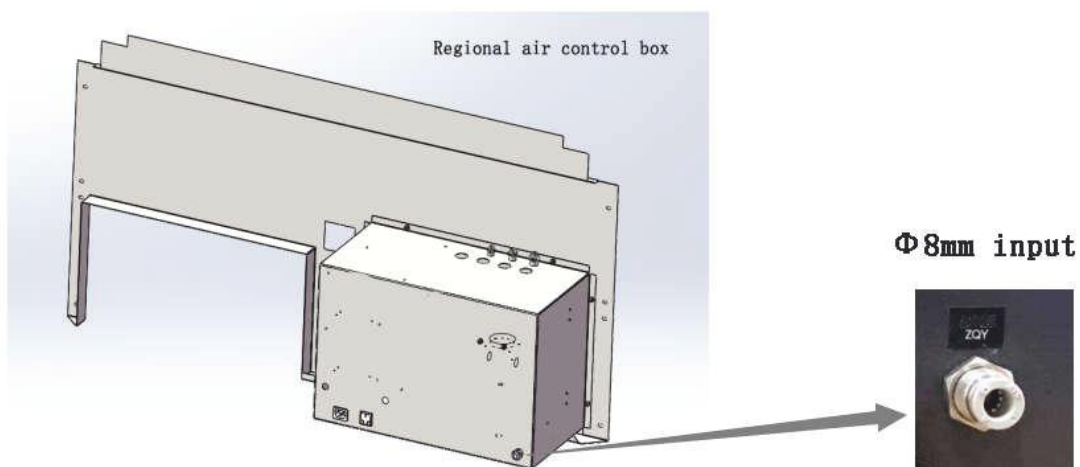
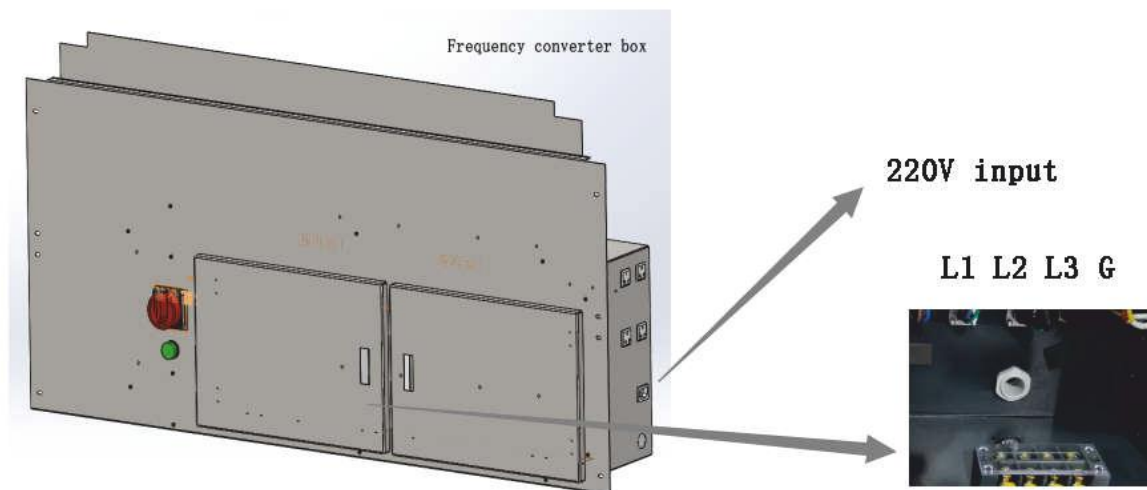

6. Cutting Head Installation

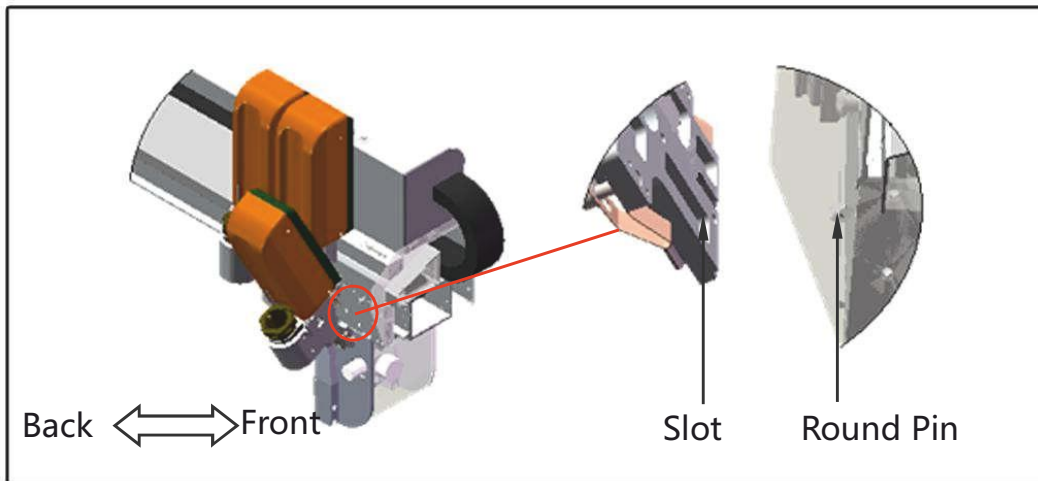

Picture 7

- Install the module in the way shown in Picture 7. Make sure the locating slot matches the round pin

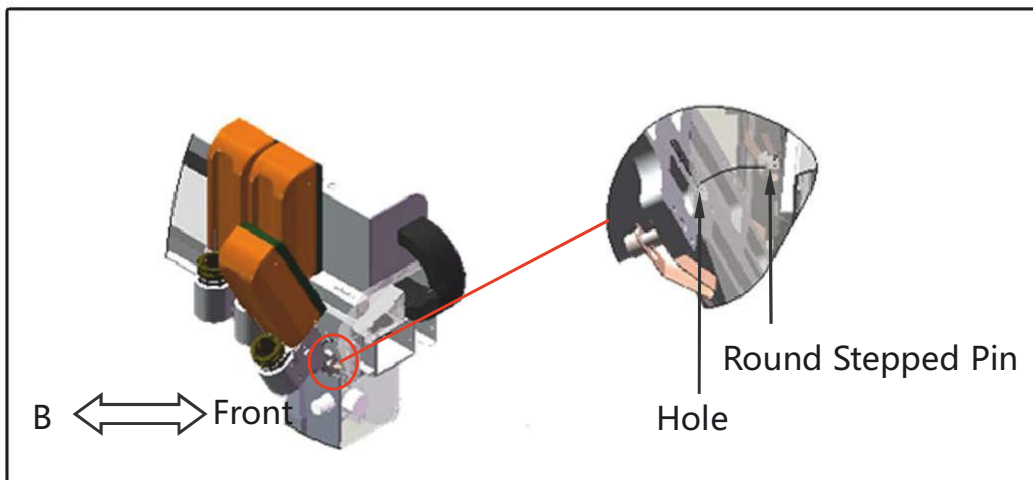

Picture 8

- Take the bottom of the module as shaft, rotate the module upward. Picture 8

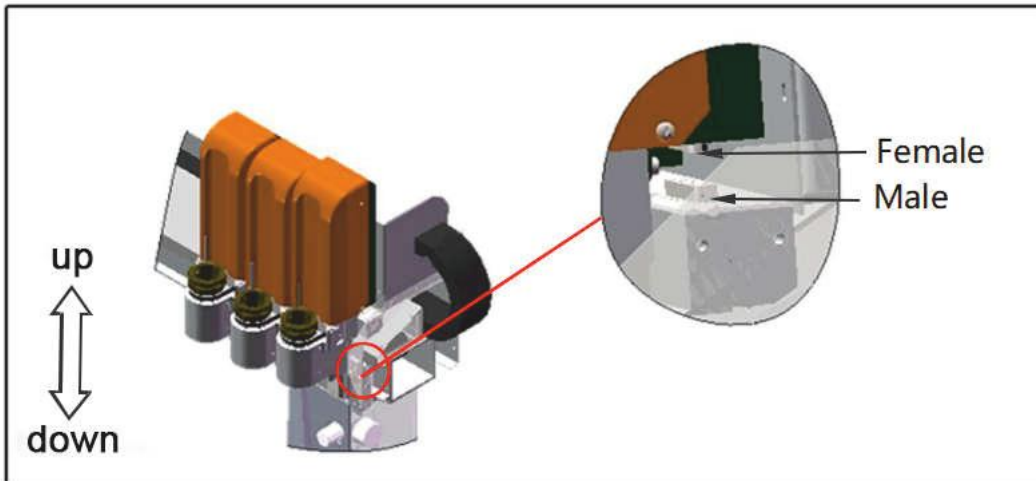

Picture 9

- Tilt the module backwards onto the module carriage, lower the module until it stops (approximately 15mm), make sure the electrical connection of tool holder and support aligned.
Picture 9

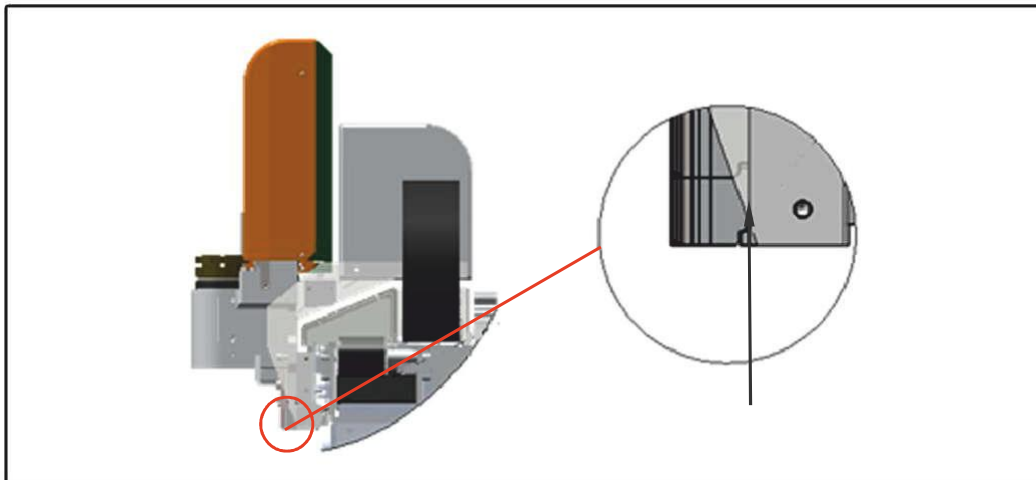

Picture 10

- Note: Place the module on the mounting ledge as shown in picture 10.

7. Tool Installation

2.4.1. Universal Cutting Tool

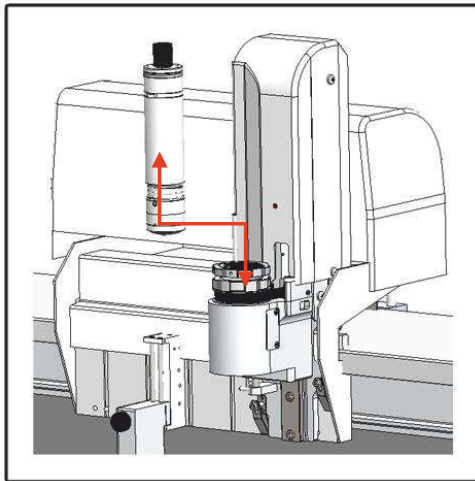

Picture 12

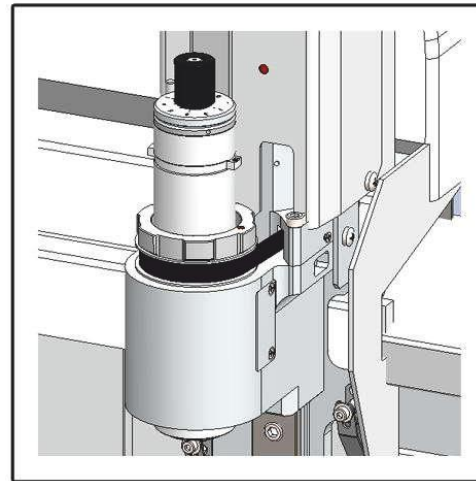

Picture 13

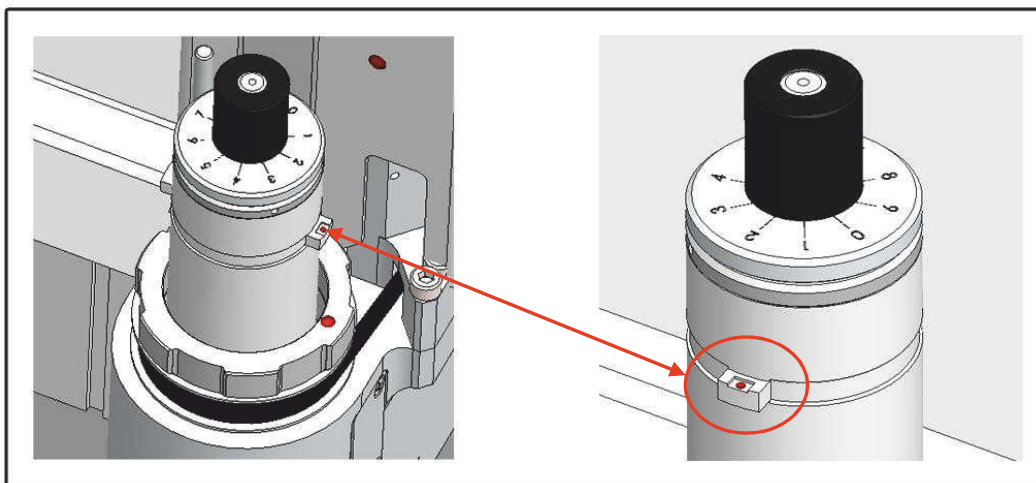

Picture 14

- Insert tangent tool (as shown picture12, picture13), The tool holder and a UCT are each marked with a red dot. The tool is in the correct position when the dots are aligned. (Picture 14)

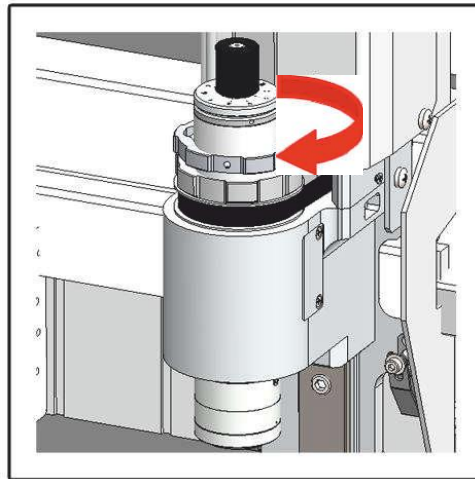

Picture 15

Fasten in clockwise direction. (Picture 15)

2.4.2. Electrical Oscillating Tool

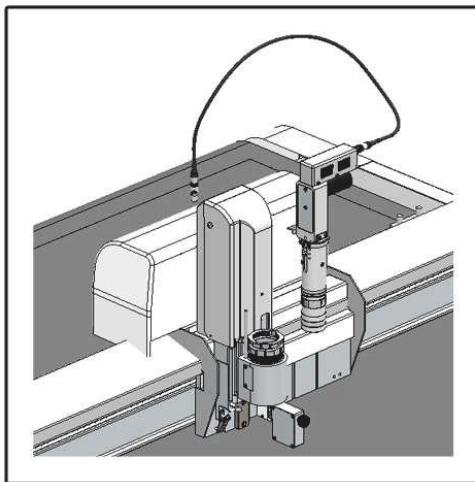

Picture 16

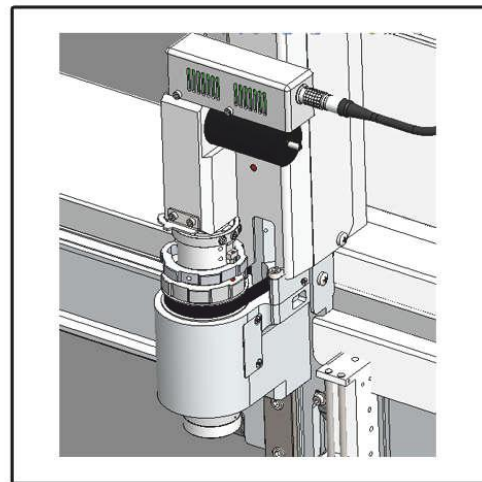

Picture 17

- Insert the EOT into the module, red point on the EOT corresponds the red point on the module. Picture 16 and 17

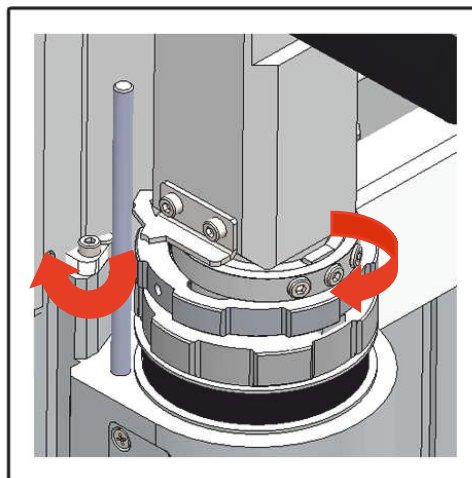

Picture 18

- Rotate the clamp clockwise to tight, rotate the EOT clockwise to match the pin. Picture 18

2.4.3. V-Cut Tool

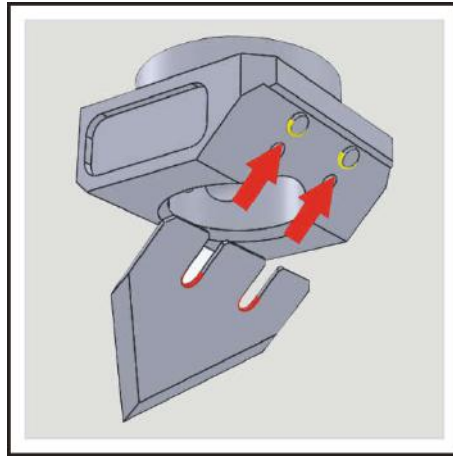

Picture 19

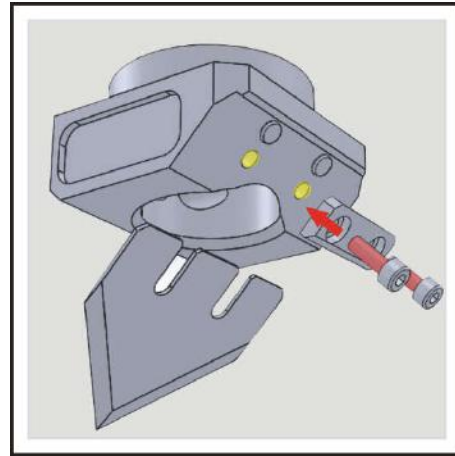

Picture 20

- First make sure blade fitting ramps of the V-cut holder, then put the kidney-shaped slot into the round positioning pins.(picture 19)
- V-cut tableting squeeze blade, screw two M4*8 bolt(picture 20),blade installation is complete.(note: If the cylindrical pin don't get stuck blade, it will lead to blade breakage and scarp)

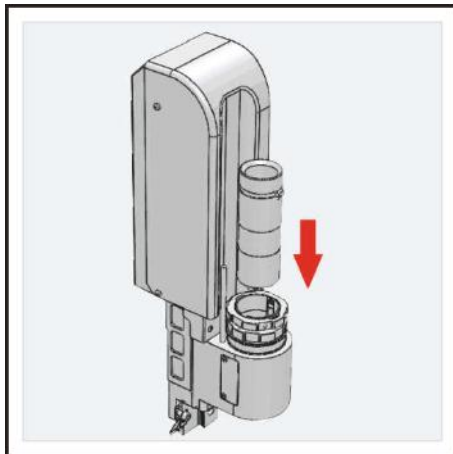

Picture 21

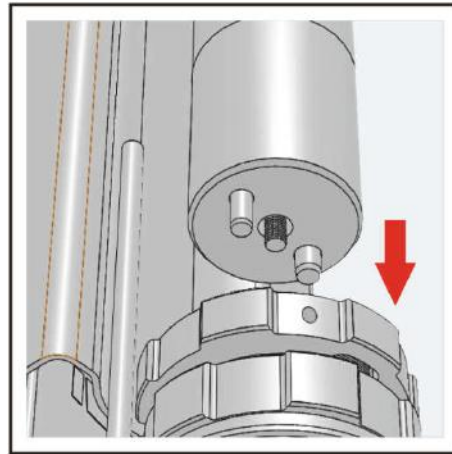

Picture 22

Put the V-CUT into the cutting holder (picture 21&22).(note: the v-cut red point corresponds to the cutting holder's red dot, otherwise it will cause installation error.

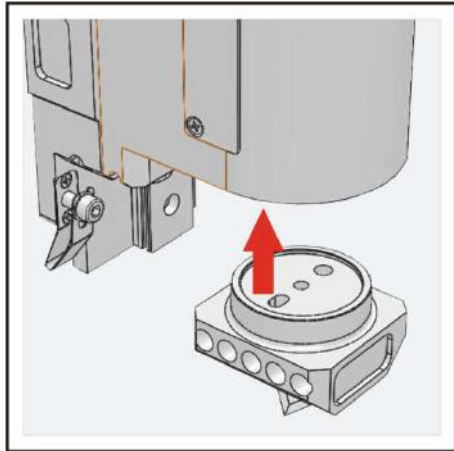

Picture 23

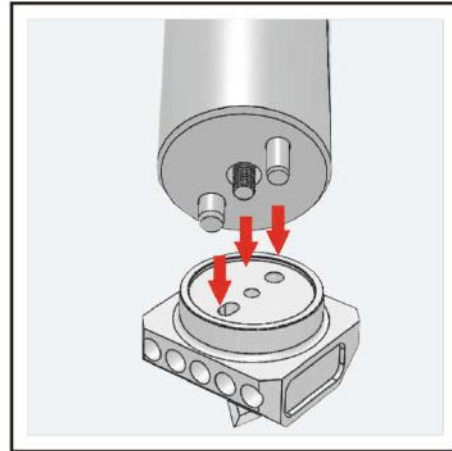

Picture 24

- Put the finished oblique turret on the bottom of oblique knife mount, make them fit (picture 23).
- There are two different cylindrical pins on the oblique knife mounts, with corresponding cylindrical pin holes, insert easily, otherwise it will cause no installed or damage parts and other issue. Oblique knife mount and oblique turret should completely butt (picture 24).

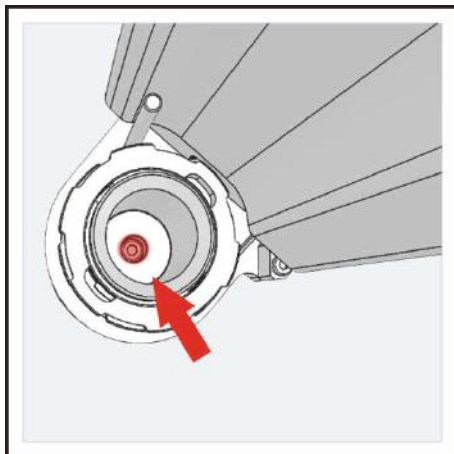

Picture 25

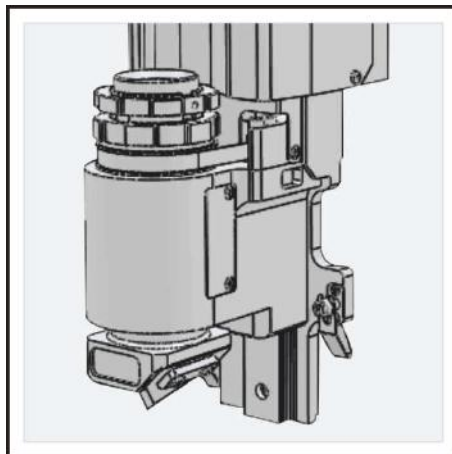

Picture 26

- Use inner hexagon 4th wrench to tighten oblique knife mount hex bolts (picture 25), oblique knife mount and oblique turret will gradually fit securely.
- Tool installation is complete (picture 26). Shake oblique turret by hands to make sure there is no gap and shake phenomenon, the installation is correct. Special attention to the blade to prevent the blade cutting hands at any time.

2.4.4. Big Creasing Tool

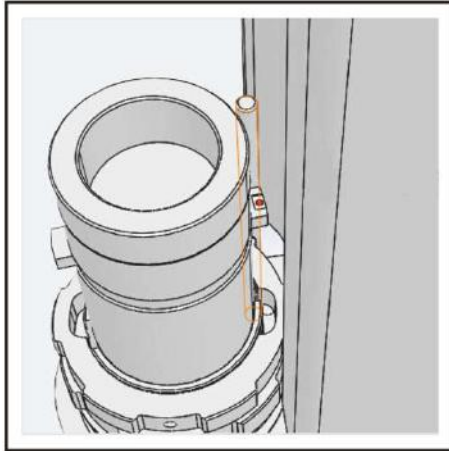

Picture 27

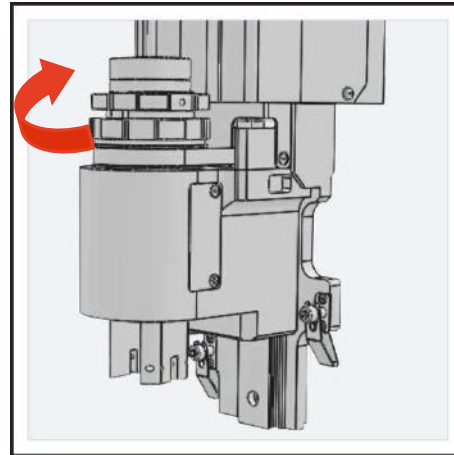

Picture 28

- Insert the big creasing wheel holder into the cutting head (Pic 27), make sure the red dot of creasing wheel holder aligned with the red dot on cutting head, then insert it into the hole on the head.
- Confirm the big creasing wheel holder into the cutting head in place, then tighten the screw on the head with clockwise (pic 28).

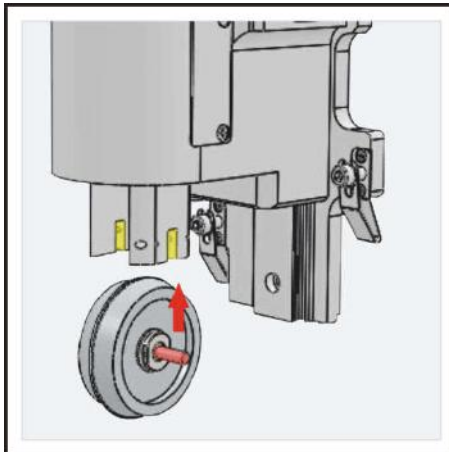

Picture 29

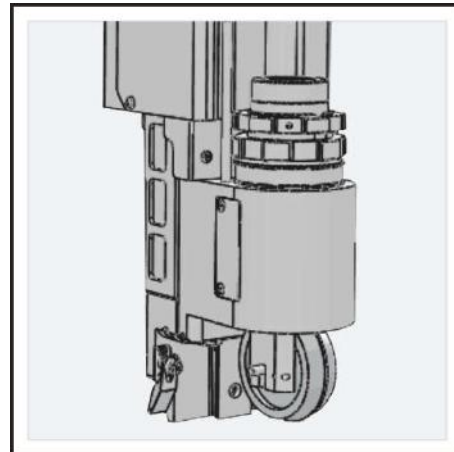

Picture 30

- Put the wheel in the rectangular slots of holder (pic 29)
- Push the wheel with hand, if no fall, it indicates installation is finished (pic 30)

2.4.5. PRT tool

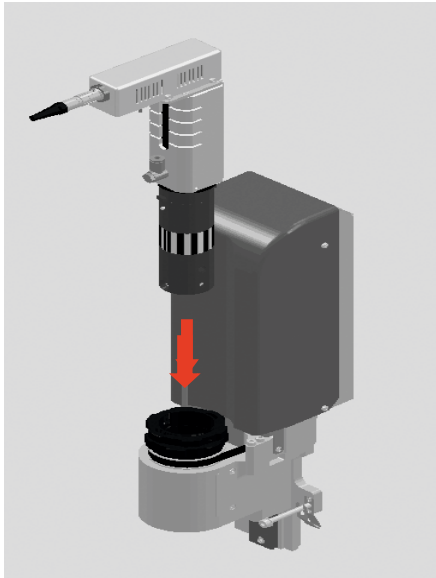

Picture 31

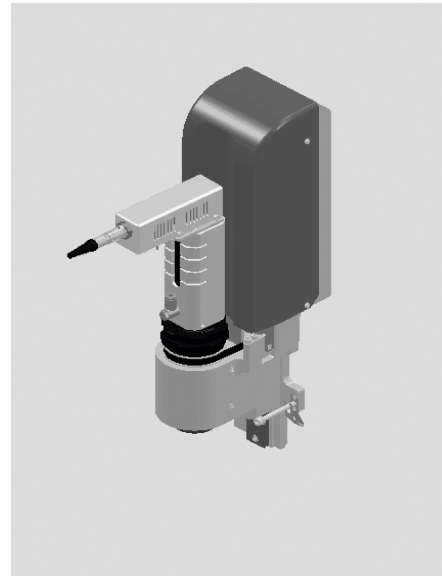

Picture 32

- Insert the PRT tool holder into the cutting head (Pic 31), make the red dot of PRT tool holder aligned with the red dot on cutting head, then insert it into the hole on the head.
- Confirm the PRT tool holder into the cutting head in place, then tighten the screw on the head with clockwise (pic 32).

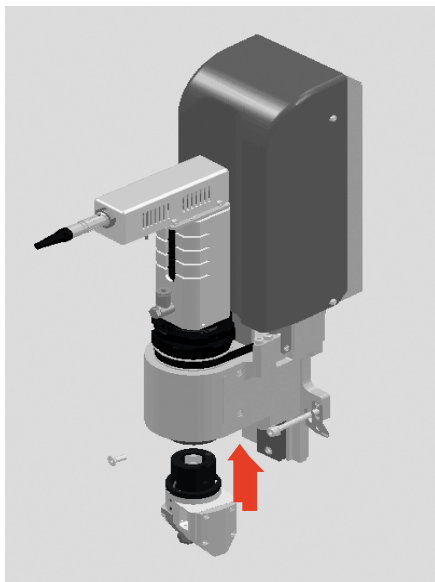

Picture 33

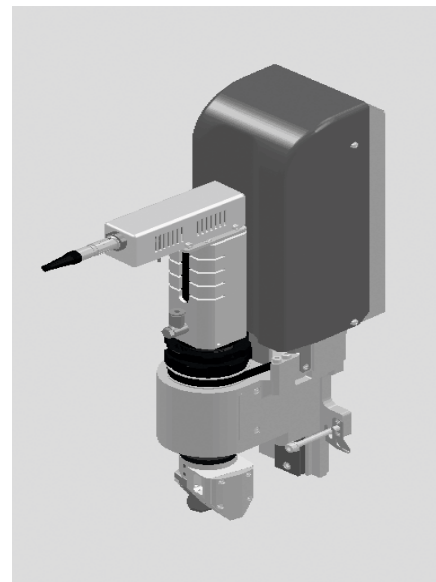

Picture 34

- Put the head part of PRT on the bottom of oblique knife mount, make them fit (picture 33).
- Use inner hexagon wrench to tighten.
- Tool installation is complete (Pic 34)

8. Operation

8.1 Preparation

- Before starting, make sure there is nobody on the working area.
- Be sure to check the platform before starting, make sure no sundry in the X/Y chain during the process.
- Check whether there is lubricating oil in Y guide.
- Check whether the air pressure reaches 0.6Mpa.
- Check whether it is correct with tools and installation.

8.2 Steps

- Power on.
- Wait for machine initialization. Procedures: Cutting head height initialization, X/Y direction initialization, cutting head rotation initialization, and cutting head move to start point.
- To avoid the blade cut the felt, please adjust the depth of tools.
- Put the materials on the table, start the vacuum pump which sucks and fixes materials on the table. If the material is breathable, a piece of plastic film is needed to be covered on the material.
- Open “ Q-Cut Digital cutting system”, import the files (DXF or PLT). The system will process the analysis of outline and the definition of cutting tool and cutting type.
- Set cutting parameter (Attention: Special parameter must be set under ERROR status in CutterServer then use “Shift+ctrl+alt+M”)
- Start the vacuum pump, move the cutting head, select laser point in CutterServer, preview the cutting area. If the material is not in the preview area or exceed, please adjust the material.
- Click cutting icon after confirmation, the machine will start to cut.
- After finishing cutting, please turn off the power and other relevant switch.

9. Maintenance

9.1 Daily Maintenance

- Check all the sockets of power as well as the connector of serial cable.
- Before cutting, make X/Y running with slow speed, then check whether has abnormal sound.
- Without cutting, start the tools which can rotate automatically (electric oscillating tool, pneumatic oscillating tool, driven rotary tool and milling), check whether the tools are OK.
- Clean everything after finishing the jobs.
- Clean up the dust and oil in Y guide daily.
- Clean up the water in the regulating valve of air compressors and equipment.
- Keep machine away from wet conditions.

9.1.1 Check the general pressure valve and waterlog.

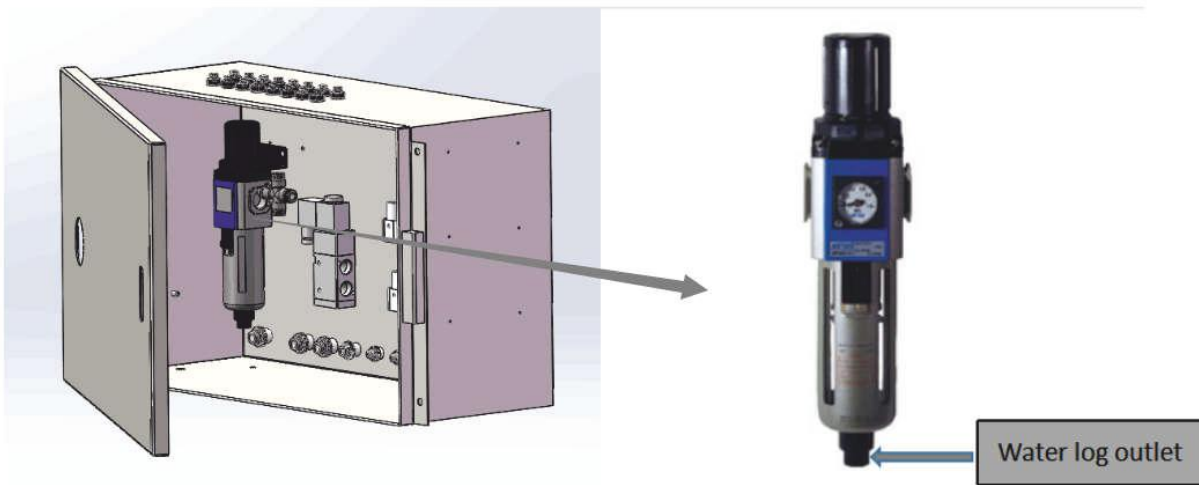

9.1.2 Clean the felt surface and the dust on the machine surface.



9.1.3 Check the chain slot.no sundries and no abnormal sound occurs.

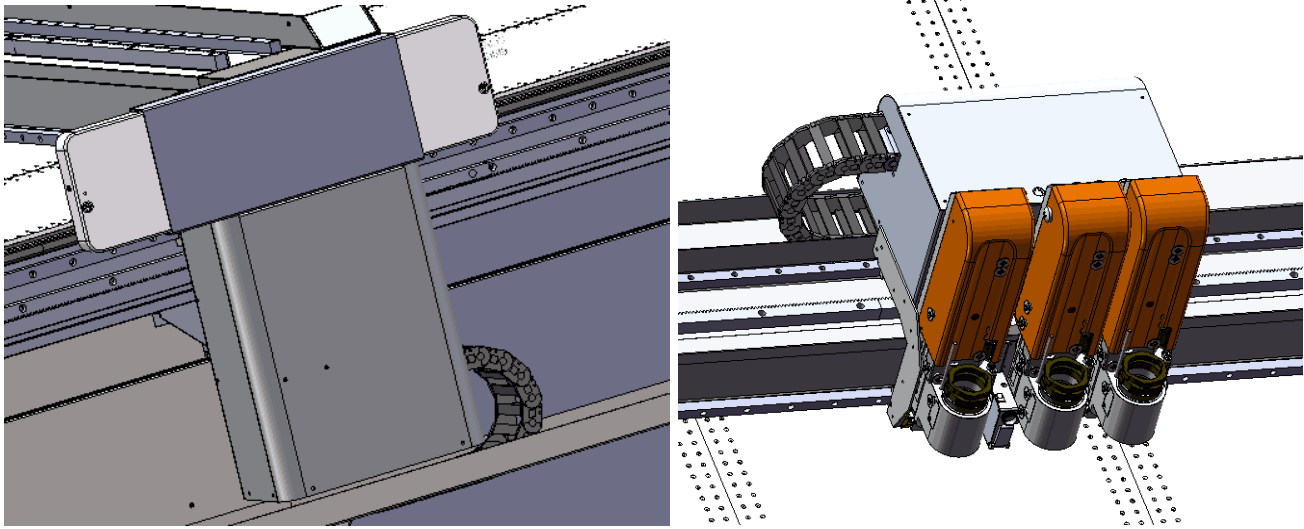

9.1.4 Clean each cutting head and confirm all the screws whether in loose condition.

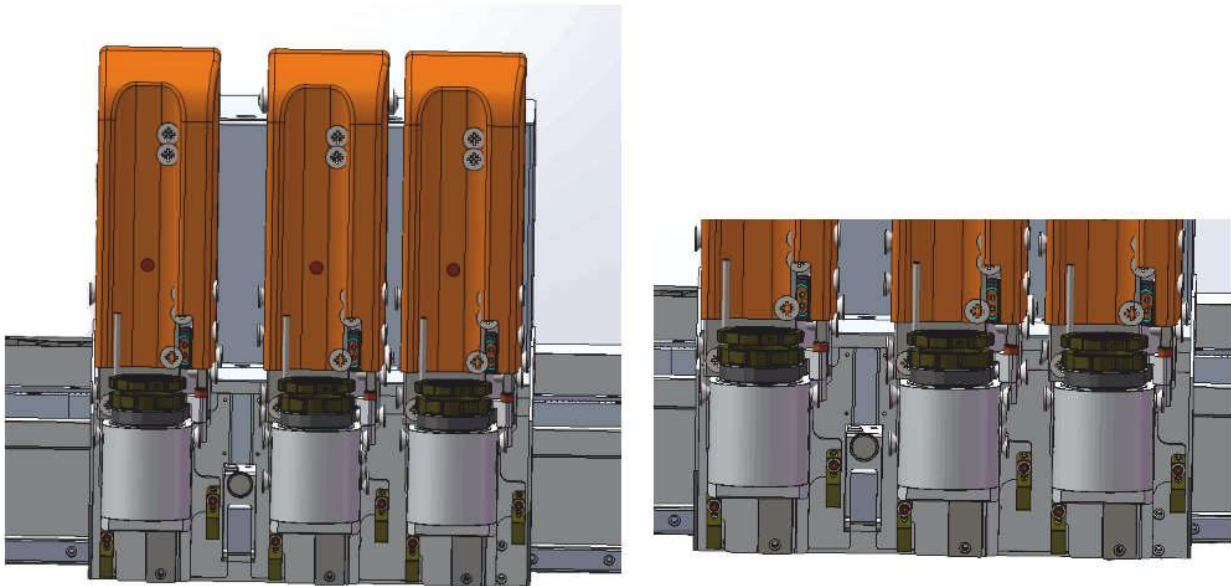

9.2 Weekly Maintenance

In order to avoid the absorption of chips during long working period, which makes small suction, operators should clean up the pump inlet weekly.

9.2.1 Check the original point sensor of X1.X2 and Y rail if the necessary.

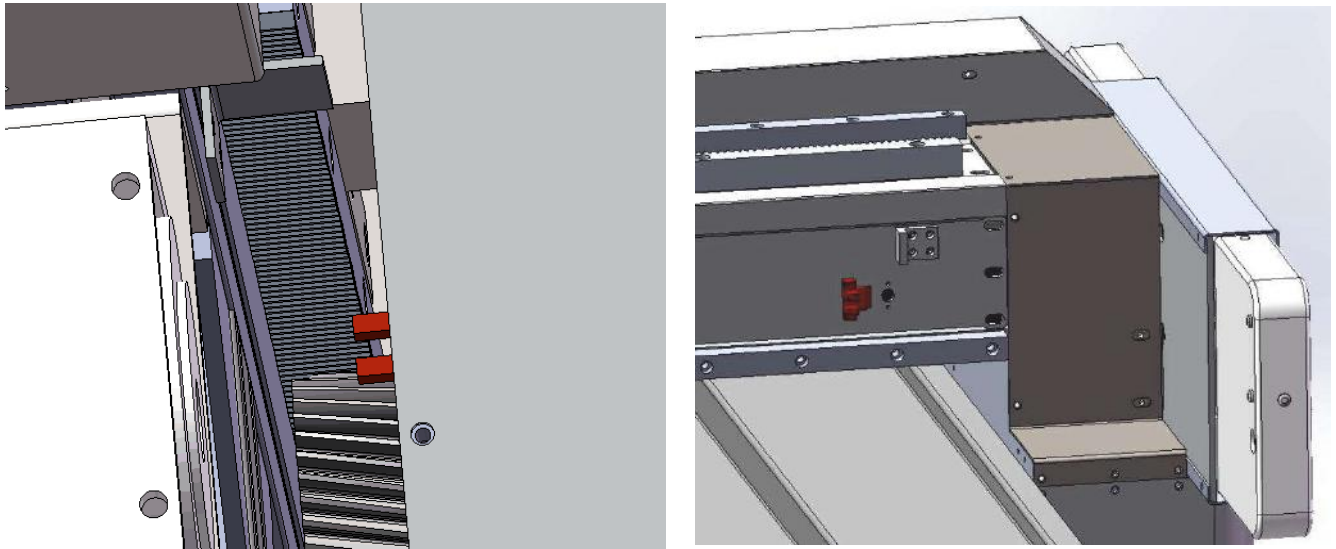

9.2.2 Clean the filter of vacuum pump.

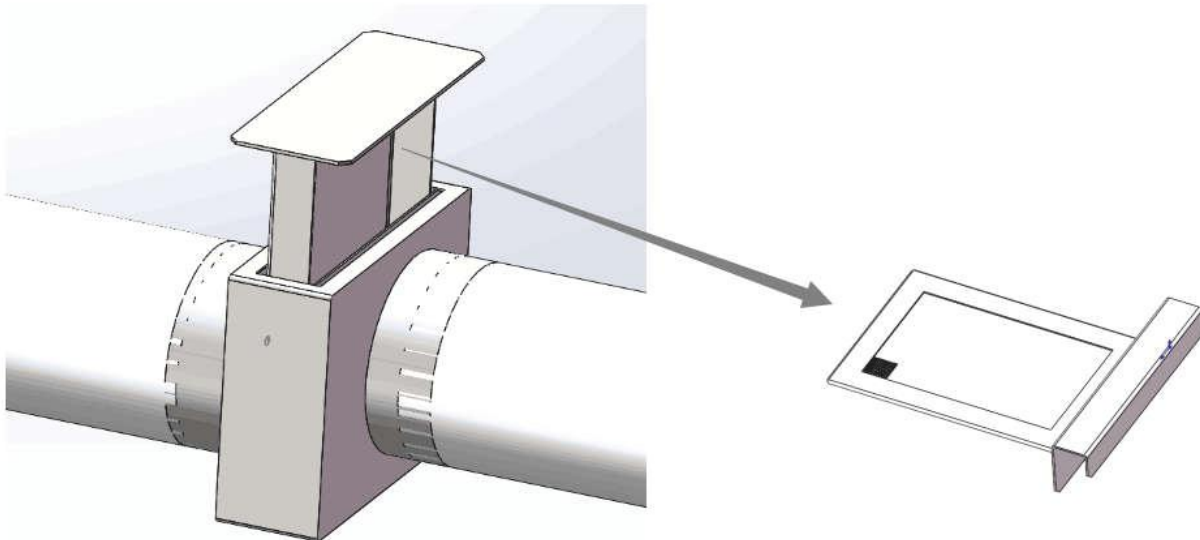

9.2.3 Check the connection of each power line if the necessary.

9.3 Monthly Maintenance

- Check the connection of felt monthly and repair it if needed to avoid the connection coming unglued and thus influencing the abnormal cutting;
- Lubricating on the rail monthly. Make sure oil will not polluting felt and other parts.

9.3.1 Check the electric leakage switch. press on electrical leakage switch, Whether under normal protection.



9.3.2 Clean X1.X2 and Y rail and add lubricating oil.

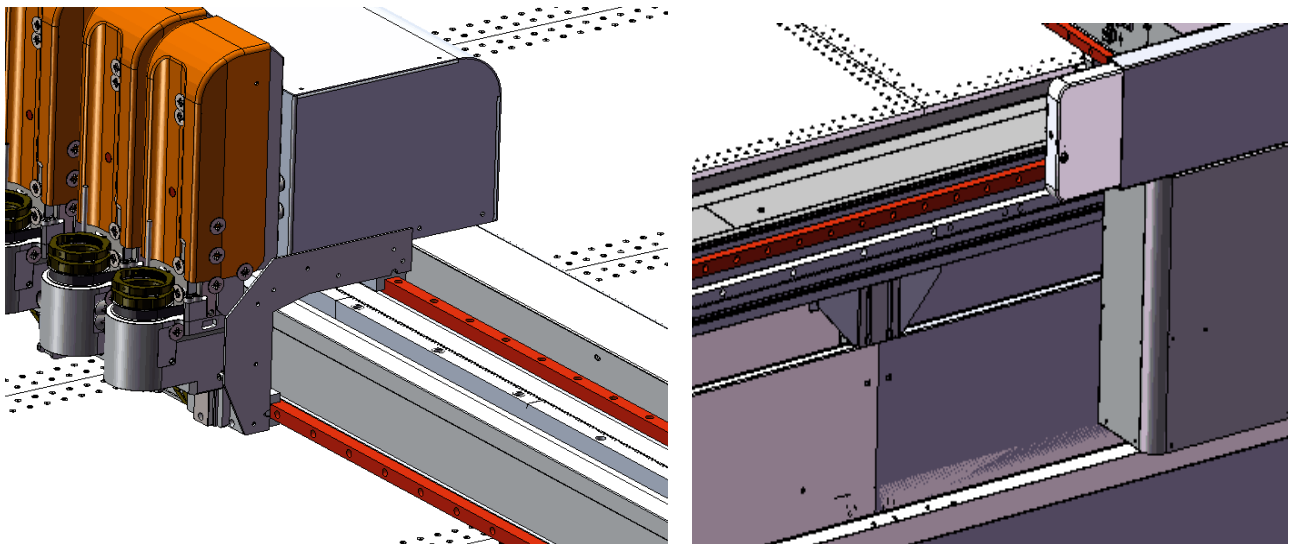

9.4 Quarterly Maintenance

Do the maintenance for the whole machine quarterly, including the cleaning, spare parts with normal, rotation parts with lubricating oil and all the screws are loose.

9.5 Annually Maintenance

Do the maintenance for the whole equipment yearly, including whether the wire is under good condition. aging, the spare part is rust and the screws are loose

10. Common Error and Troubleshooting

Item	Common error	Troubleshooting
1	Cutter cannot start	<ol style="list-style-type: none"> 1. Check whether the circuit breaker tripped. 2. Check whether the fuse is burned out. 3. Check whether the red switch is broken. 4. Check the plug connected to electrical box interface with a multi meter. Check whether the circuit of the 220V power
2	Cutter suction force weakened, failed to fix the materials well	<ol style="list-style-type: none"> 1. Put one piece of plastic film on the surface of the materials if they are breathable. 2. Clean the vacuum entrance filter net if it is blocked. 3. Check whether there's leakage on the vacuum plate and pipes.
3	Materials could not cut though	<ol style="list-style-type: none"> 1. Knife height not enough; Increase cutting knife depth. 2. Change new blades. 3. Check the flatness of the cutting table; Contact services if needed. 4. Materials cannot totally cut off; Put a piece of perforated paper on the table surface.
4	Could not cut off patterns at the corners	Open the dialogue box of Cutter Parameter Setting, Reset the Knife Up Compensation and Knife Down Compensation
5	Files sent CutterServer failed	Use Diagnose function in CutterServer, to check the DSP version.

11. Safety Attentions

- GND electrical wire connected to the ground.
- Use the required specification wires for electric power connection, as per the big cutter power.
- Check the synchronous belt before switch on the machine, in case it's blocked by materials fragments.
- Press the Emergency stop button or switch off the power in case of emergency.
- Operators and staffs shall not reach into the danger area when the cutter is working.
- In principle, any troubleshooting work or inspection on the cutter is to be carried out only when the power is off.
- Cutting heads adjustment and tools changes shall be carried out only when it is stopped.

12. Other Information

12.1 Products Details

Name	
Model	
Date	
Serial No	
QC	

12.2 Warranty Card

Products Information			
Model		Serial No	
Warranty Time		Purchase Time	
Customer Information			
Attention		Tell	
Company Name		Address	
E-mail			

Note:

- If you need to consult, repair, or replace objects, please call our company's service telephone number. Please fill the form and keep the warranty card, as the warranty service certificate for you.
- The warranty is one year (equipment installation shall prevail).

12.3 Product Maintenance Details

Liyu International provide life-long maintenance of equipment, free warranty for oneyear. If the fault is caused by customer, the cost of the parts will be charged after repair.

The company on-site service will charge the cost and maintenance fee if it is out of warranty time

Do not disassemble the machine, please call professional maintenance staff, to avoid danger or damage to the equipment.

Service line: +90-532-5027522

Website: www.liyuprinter.com

Products	Q-CutHigh speed cutting machine	Product No.	
Manual	Q-Cut Cutting machine	Date:	2018-12-28
Version	M1.0	Audit	

12.4 Statement

- This manual copyright belongs to Liyu International (hereinafter referred to as Liyu International)
- Liyu International will not make any guarantee for this manual, Liyu International will not beresponsible for this usermanual when cause the misunder standing.
- Liyu International reserves the right of final interpretation if the products users bought has the discrepancy with the manual.