

# **LIYU KC\_Ricoh\_G5 Series Digital Flatbed Inkjet Printer Operation Manual**

**First Edition LIYU KC\_Ricoh\_G5 Series Digital Flatbed Inkjet Printer Operation Manual July 1st 2018. All rights reserved for Anhui LIYU Computer Equipment Manufacturing Co., Ltd. Anhui LIYU Computer Equipment Manufacturing Co., Ltd. has the right to revise the technical specification and various contents in the Manual without any notice and shall not be liable for any damages (including causal damages) due to reliance on the contents in the Manual (including such mistakes as misprints, miscalculation and list errors).**

## Introduction

Thank you very much for purchasing our LIYU KC Series Flatbed Inkjet Printer (hereinafter referred to as Flatbed Inkjet Printer). Please carefully read the Manual before using the Flatbed Inkjet Printer and put the Manual at the place within easy reach at any time. This flatbed inkjet printer is one that uses environmental UV ink with maximum width of 2.5m\*1.2m, 3m\*2m respectively. The operational manual describes the features of the printer, parts name, information that should be known before using the equipment and the basic operation, for instance, how to switch on and off and how to set various parameters of the printer. Please carefully read the following contents before reading Chapter One: Safety Precautions and Operation Cautions.

## Technical specifications

RICOH G5 print heads are applied to KC\_Ricoh\_G5 series flatbed inkjet printers by using system A or A+, with the layout code suffixes of the print head are S and A+, respectively. Please decide machine types according to the following table:

- *Machine Model List*

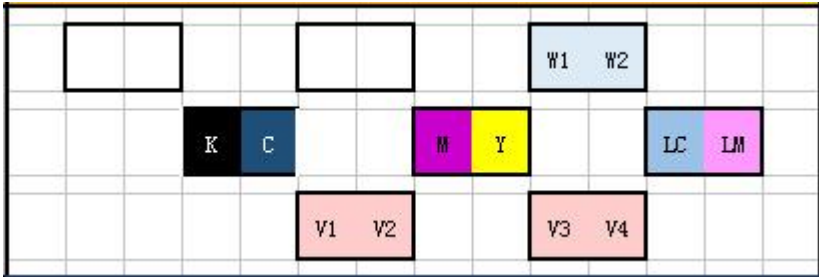
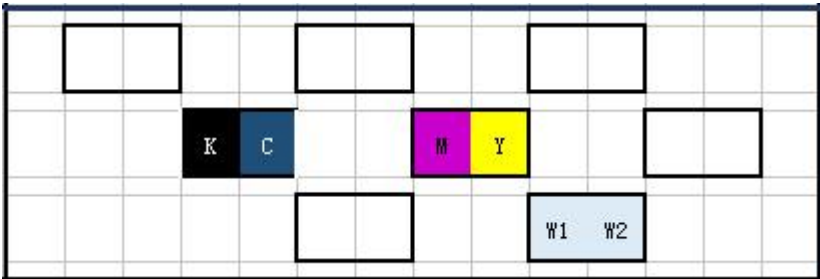
Machine Model	Layout Diagram and Code of the Print Head
<p>KC251206-RA</p> <p>KC302006-RA</p>	 <p>(S062-W021-V044)_S</p>
<p>KC251203-RA</p> <p>KC302003-RA</p>	 <p>(F042-W024)_S / (F042-W024)_A+</p>

**KC251204-RA**

**KC302004-RA**

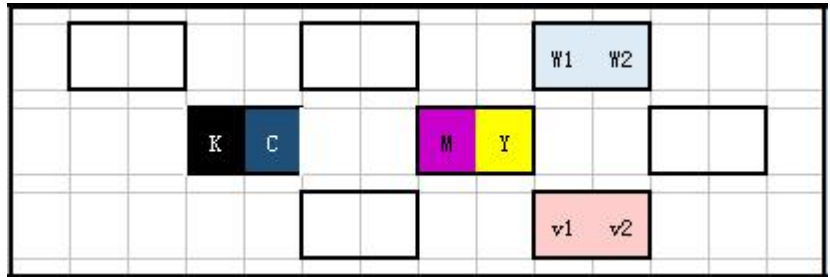

**(F042-W021-V024)\_S / (F042-W021-V024)\_A+**

**KC251205-RA**

**KC302005-RA**

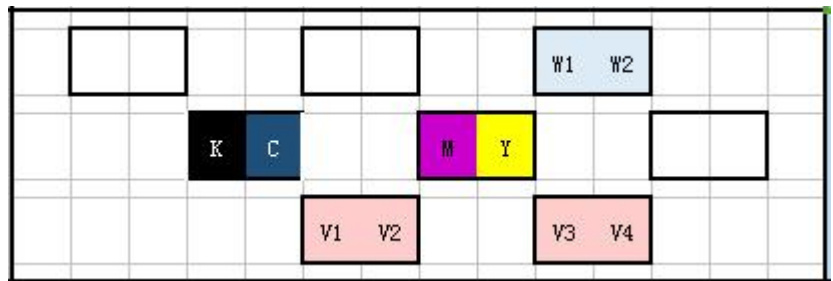

**(F042-W021-V044)\_S**

**KC251205-RA**

**KC302005-RA**

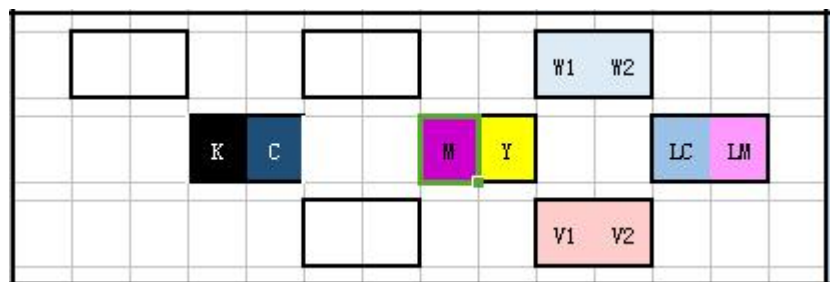

**(S062-W021-V024)\_S**

**KC251206-RA**

**KC302006-RA**

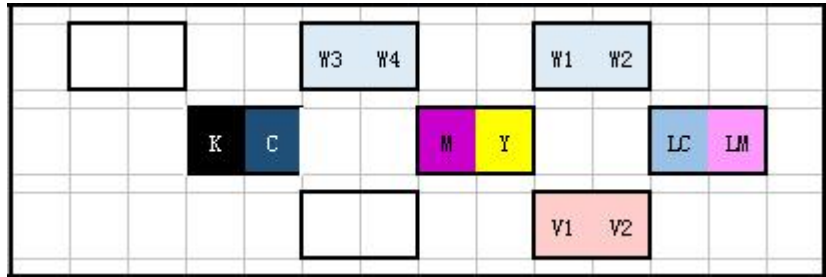

**(S062-W041-V024)\_S**

**KC251208-RA**

**KC302008-RA**

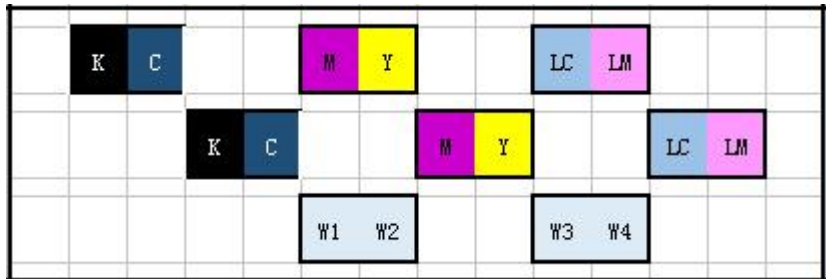

**(S123-W044)\_S**

**KC251208-RA**

**KC302008-RA**

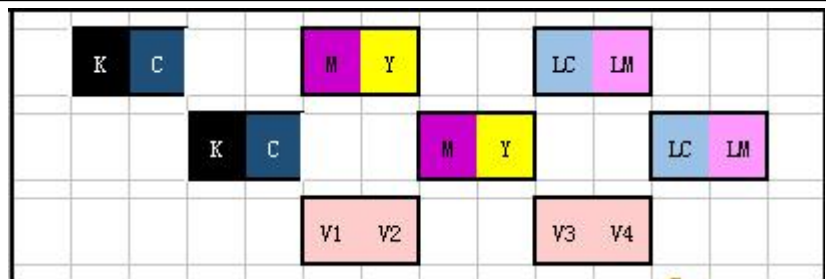

**(S123-V044)\_S**

KC251206-RA

KC302006-RA

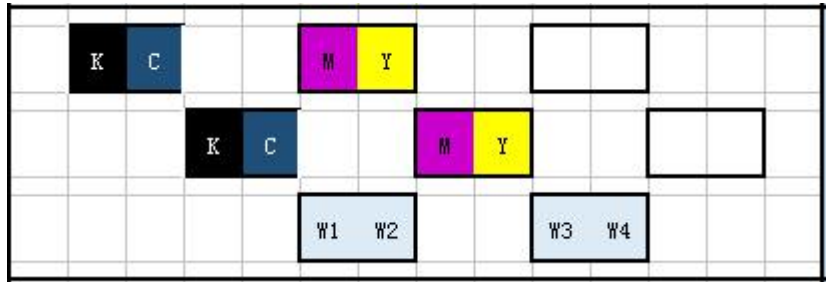

(F083-W044)\_S

KC251206-RA

KC302006-RA

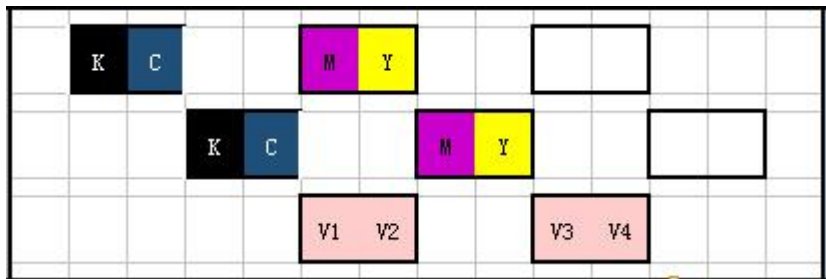

(F083-V044)\_S

KC251206-RA

KC302006-RA

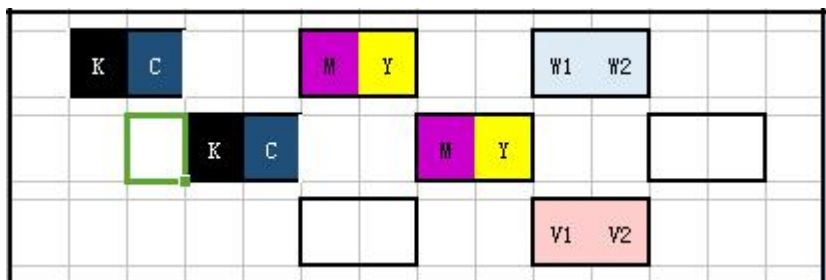

(F083-W021-V024)\_S

**KC251205-RA**

**KC302005-RA**

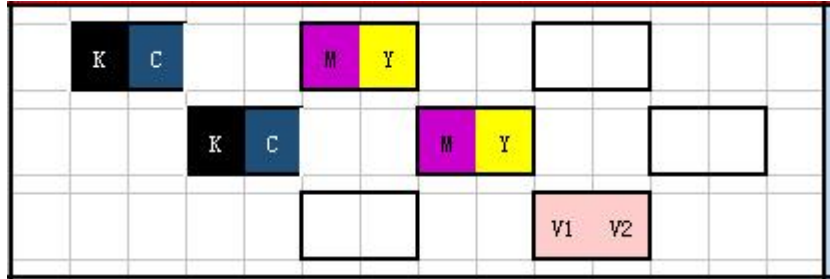

**(F083-V024)\_S**

**KC251207-RA**

**KC302007-RA**

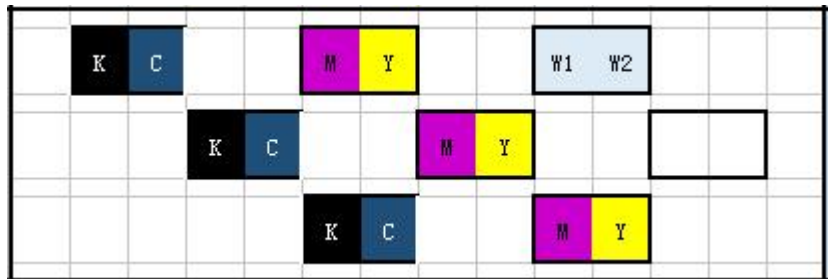

**(F127-W021)\_S**

**KC251208-RA**

**KC302008-RA**

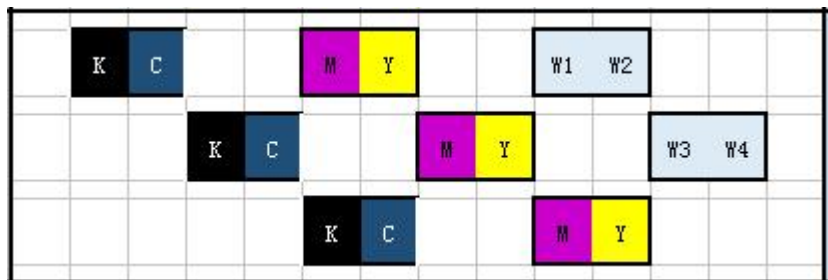

**(F127-W043)\_S**

**KC251204-RA**

**KC302004-RA**

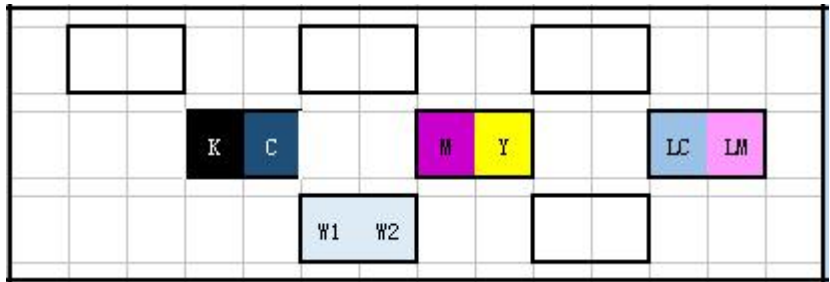

**(S062-W024)\_S / (S062-W024)\_A+**

**KC251204-RA**

**KC302004-RA**

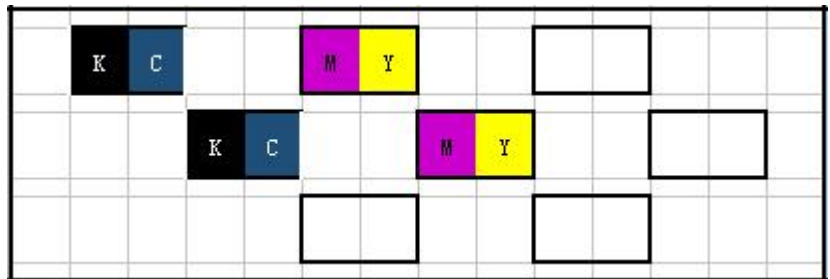

**(F083)\_S / (F083)\_A+**

**KC251202-RA**

**KC302002-RA**

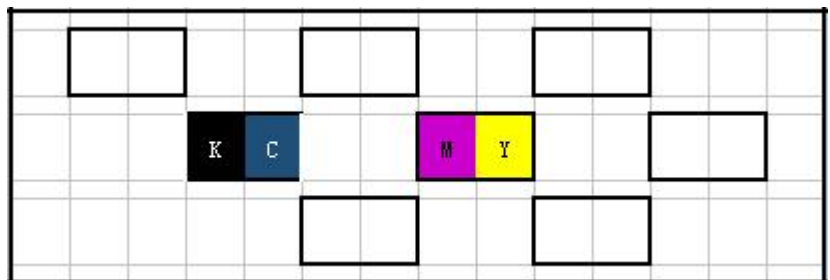

**(F042)\_A+**



● *List of Main Technical Specifications*

■ **Machine Parameters**

<b>Machine Model</b>	<b>KC_2512/ KC_3020</b>
<b>Print Technology</b>	<b>Piezo continuous drop-on demand(DOD)</b>
<b>Type of Print Head</b>	<b>RICOH G5</b>
<b>Print Head Control</b>	<b>Use software to adjust the temperature and voltage of the print head.</b>
<b>Print head Configuration</b>	<b>See the layout diagram and code of the print head</b>
<b>Maximum Printing Size</b>	<b>2.5m*1.2m/3m*2m</b>
<b>Maximum Resolution</b>	<b>720*1200 dpi</b>
<b>Fastest Print Mode and Efficiency</b>	<b>720*900 3 pass      26 m<sup>2</sup> /28 m<sup>2</sup></b>
<b>Ink Type</b>	<b>UV Ink</b>
<b>Color Profile</b>	<b>K C M Y Lc Lm W V (optional)</b>
<b>Ink Supply System</b>	<b>Automatic continuous ink supply with vacuum negative pressure</b>
<b>Media Absorption</b>	<b>Table vacuum absorption, segmented control</b>
<b>Table Pressure</b>	<b>25kg/m<sup>2</sup></b>
<b>Drying Device</b>	<b>LED_UV lamp solidification</b>
<b>Package Size</b>	<b>5430*2320*1830 /6040*3020*1870</b>
<b>Machine Size</b>	<b>4970*2180*1520;5520*2955*1520</b>
<b>Machine Weight</b>	<b>1.6t/1.9t</b>
<b>Printing Interface</b>	<b>USB3.0</b>
<b>Power interface</b>	<b>Mainframe 220V±10% 50HZ 5A Fan 220V±10% 50HZ 12A UV lamp 220V±10% 50HZ 9A</b>
<b>Environmental Requirements</b>	<b>Temperature 23 ~ 26      Relative humidity 40% ~ 80%</b>
<b>RIP Software</b>	<b>Photo print</b>
<b>Machine Characteristics</b>	<b>High-precision and high-speed print heads, separated intelligent negative-pressure ink-supply system, human engineering mechanics design, THK noiseless guide, integrated computing operation desk, LED cold light source solidification</b>

## ■ Printing Efficiency List

The printing speed of KC series flatbed printer is mainly decided by numbers of print heads in rows and printing modes. This table takes two Ricoh G5 print heads and four colors as a sample.

<b>KC_Ricoh_G5 Series</b>	
<b>Printing Mode</b>	<b>Working Efficiency 2512/3020</b>
<b>Draft Mode</b> (High-precision, without feather 720*1200 4pass)	<b>20.8 m<sup>2</sup>/22 m<sup>2</sup></b>
<b>Working Mode</b> (High-precision, middle feather 720*900 6pass)	<b>13 m<sup>2</sup>/15 m<sup>2</sup></b>
<b>High Precision Model</b> (High-precision, strong feather 720*1200 8pass)	<b>9 m<sup>2</sup>/12 m<sup>2</sup></b>

## Important particulars

The negligence of precautions mentioned below may seriously affect the working conditions of the equipment, equipment service life or the service life of relevant parts, or even cause the permanent damages of relevant parts, and may endanger staff's physical and mental health in some cases. Please operate in strict accordance with instructions.

1. Please carefully read the requirements for working space and working environment of the machine in this manual and strictly abide by the requirements. Otherwise, it will affect the working state of the machine, machine service life or service life of parts, or even endanger staff's physical health;
2. Please use the ink designated by the manufacturer, otherwise, it may affect the printing effects or even cause the permanent damage of print head;
3. During the operation and maintenance process of the machine, please be sure to avoid the contact of ink and non-cleaning fluid, so as to prevent the ink from any chemical reaction which may cause machine damage;
4. Since the waste fluid generated from the machine will pollute the environment, please properly dispose of the waste fluid in accordance with the requirements of local environmental protection department;
5. The auxiliary ink box, filter, ink pump, air pump, liquid pump, refill tube and print heads of the machine all belong to wearing parts and shall be replaced periodically as per the service condition.

## Safety precautions

To ensure that operators will properly use the equipment and prevent equipment damages and unnecessary casualties, please carefully read the following safety precautions:

Please use the voltage as specified on the nameplate and never plug several devices into one power outlet at the same time to avoid fire disaster.

Please check and ensure the equipment has been grounded reliably. Otherwise, disturbance may be caused and lead to abnormal image printing of the machine.

Never dismantle or transform the equipment by yourself, otherwise, such accidents as fire disaster, electric shock and other accidents may be caused.

Keep the circuit control section of the equipment away from metal objects or liquid, otherwise, it will cause circuit board damage, fire disaster or other accidents.

Never connect the power line of the equipment with wet hands, otherwise electric shock may occur.

In the event of the following situations, please switch off the equipment and contact the local dealer if necessary:

1. The switch is insensitive or doesn't work.
2. When the inkjet printer makes abnormal sound or produces smoke.
3. When any metal object or liquid splashes into the electric control part of the equipment.
4. When problems that operators fail to settle arise.

## Operation precautions

### Power supply

- 1. Inkjet printer shall be installed near the power source convenient to use and the connecting outlet must be solid and reliable.**
- 2. Relatively stable power supply in accordance with technical specification of inkjet printer shall be used, and it should be mandatory to install the voltage stabilizer, and the USP (uninterruptible power supply) is the recommended one.**
- 3. Connect the power line to a separate outlet and never share the same power outlet with other equipment.**
- 4. Pay attention to the order of power on and off so as to avoid damages to print head.**
- 5. In case of unstable local voltage, please use voltage stabilizer to guarantee the stable voltage and choose the famous brand products, because inferior products may cause equipment fault or damage electrical component of the equipment (including print head).**

### Inkjet Printer

- 1. Don't place any undesired objects on the platform of the inkjet printer so as to avoid damages to print head.**
- 2. In case of any maintenance for the machine as regards electrical control, please be sure to disconnect the power of inkjet printer.**
- 3. Never touch the surface of print head with hands or hard objects.**

### Regular Inspection and Maintenance

- ✧ Fill lithium base grease in mechanical parts with grease gun on a regular basis, and fill in the ink carriage linear guide once for every week under normal printing.**
- ✧ See contents in Chapter Maintenance and Service for maintenance method of ink and print head.**

# Content

<b>Introduction.....</b>	<b>2</b>
<b>Technical specifications.....</b>	<b>3</b>
● Machine Model List.....	3
● List of Main Technical Specifications.....	9
■ Machine Parameters.....	9
■ Printing Efficiency List.....	10
<b>Important particulars.....</b>	<b>11</b>
<b>Safety precautions.....</b>	<b>12</b>
<b>Operation precautions.....</b>	<b>13</b>
<b>Content.....</b>	<b>14</b>
<b>Chapter 1: Introduction to Basic Knowledge.....</b>	<b>16</b>
● Working conditions.....	17
■ Working space.....	17
■ Environmental Requirements.....	17
■ Computer configuration requirements.....	18
● Machine unpacking and floor installation.....	19
● Appearance, name and functions of parts.....	22
■ KC_2512 Front view.....	22
■ KC_2512 Back View.....	25
■ Carriage view.....	26
● Consumables.....	28
■ Printing Media.....	28
■ Ink and Cleaning Fluid.....	29
■ Maintenance Tools.....	29
● Computer connection.....	31
■ Installation environment for PrintManager of KC_Ricoh Series.....	31
■ Installation steps of PrintManager.....	31
● Installation and adjustment of print head.....	34
■ Introduction of Ricoh G5 print head.....	34
■ Print head installation.....	34
● Power ON/OFF of the Machine KC_Ricoh.....	40
■ Power ON.....	40
■ Power OFF.....	40
● Add ink and fill the print head with ink.....	41
■ Inject ink into the main ink tank.....	41
■ Inject ink into the auxiliary ink box.....	41
■ Fill the print head with ink.....	42
● Positive pressure ink.....	43
● Negative pressure adjustment.....	43
<b>Chapter 3 System Function.....</b>	<b>46</b>
● Introduction to KC_Ricoh_G5 Ricoh System Function.....	47

■ Core component.....	47
■ PC.....	47
■ MainBoard.....	47
■ MAP Board.....	49
■ HB Board.....	50
■ Ricoh G5.....	51
<b>Chapter 4 Maintenance and Service.....</b>	<b>52</b>
● Daily maintenance instructions.....	53
● Print head maintenance instructions.....	53
● Ink use guidelines.....	55

**Refer to document 1 *Ricoh\_G5 System\_PrintManager Operation Manual***

**Refer to document 2 *Setting Method of Panasonic DP-101 Digital Vacuum Pressure Sensor***

# Chapter 1: Introduction to Basic Knowledge

---

This chapter dwells on the necessary information for inkjet printer operation. Please understand the necessary information before reading other chapters. Contents of this chapter:

- Working conditions
- Working space
- Environmental requirements
- Computer configuration requirements
- Appearance, name and functions of parts
  - KC2512 Front view
  - KC2512 Back view
  - Carriage view
- Machine unpacking and floor installation
- Consumables
  - Printing media
  - Ink and cleaning fluid
  - Maintenance tools



## ● Working conditions

### ■ Working space

There must be enough space surrounding the flatbed printer so as to facilitate replacement of some commonly used spare parts, drawings output and ventilation. In addition, make room for maintenance (as shown below) with the aim of printer repair or spare parts replacement.

Installation and maintenance space is shown in the following figure:

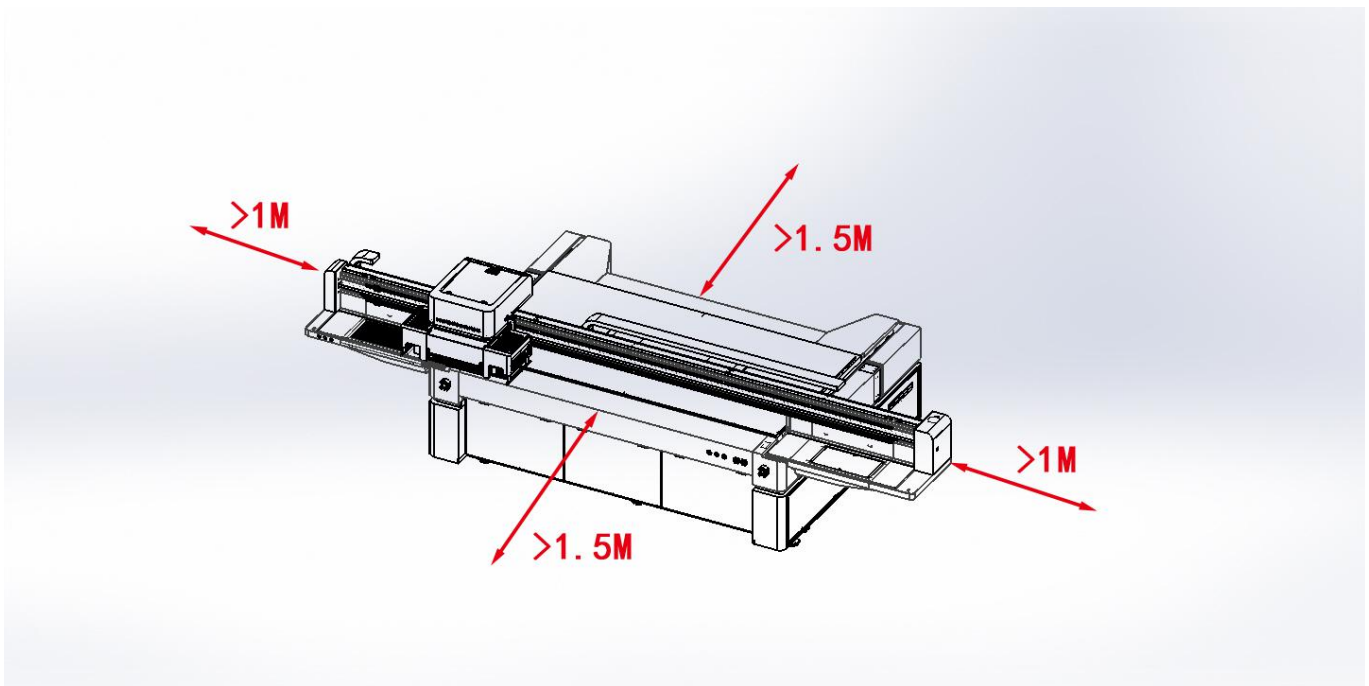

### ■ Environmental Requirements

The optimal working temperature and humidity of the equipment: temperature 23 - 26 , humidity 40% RH ~80% RH.

Please try to keep the equipment working under the optimal working temperature and humidity; otherwise, the printing quality may drop and the service life of the machine may reduce.

Don't install the machine at the following locations:

- ✧ In direct sunlight
- ✧ **Location with vibration**
- ✧ **Dusty places**
- ✧ **Location with drastic temperature variation**
- ✧ **Location with great air mobility**
- ✧ **Near the air-conditioning or heater**
- ✧ **Place likely to be wetted**
- ✧ **Place likely to produce other polluting gas**
- ✧ **Unstable location**

#### ■ **Computer configuration requirements**

The minimum configuration requirements for the software operation of the product are as follows:

**CPU: INTEL i5 or above.**

**Display card: Graphic display card with video memory above 1G.**

**Memory: Memory above 8G. Other: CD—ROM drive.**

**Hard disk: Over 50 G room is left, please use NTFS format as the hard disk format.**

**Operating system: WIN7 64-bit Professional or Ultimate**

- ***Machine unpacking and floor installation***

1. Fastening steel strips and fixed bolts are attached on the packing box, please cut off the steel strips before unpacking. Remove the fixed bolts of the packing box in turn, 5 sides in total, take down the side plate and top cap of the packing box; Some of the machines will be sent out according to the order requirements, only having the packing chassis fixed machine, with rain cloth and tin foil attached on it, the positions of the steel strip bolts are as shown in the red logo below:



2. Please remove the fixed support and the fixed bearing.

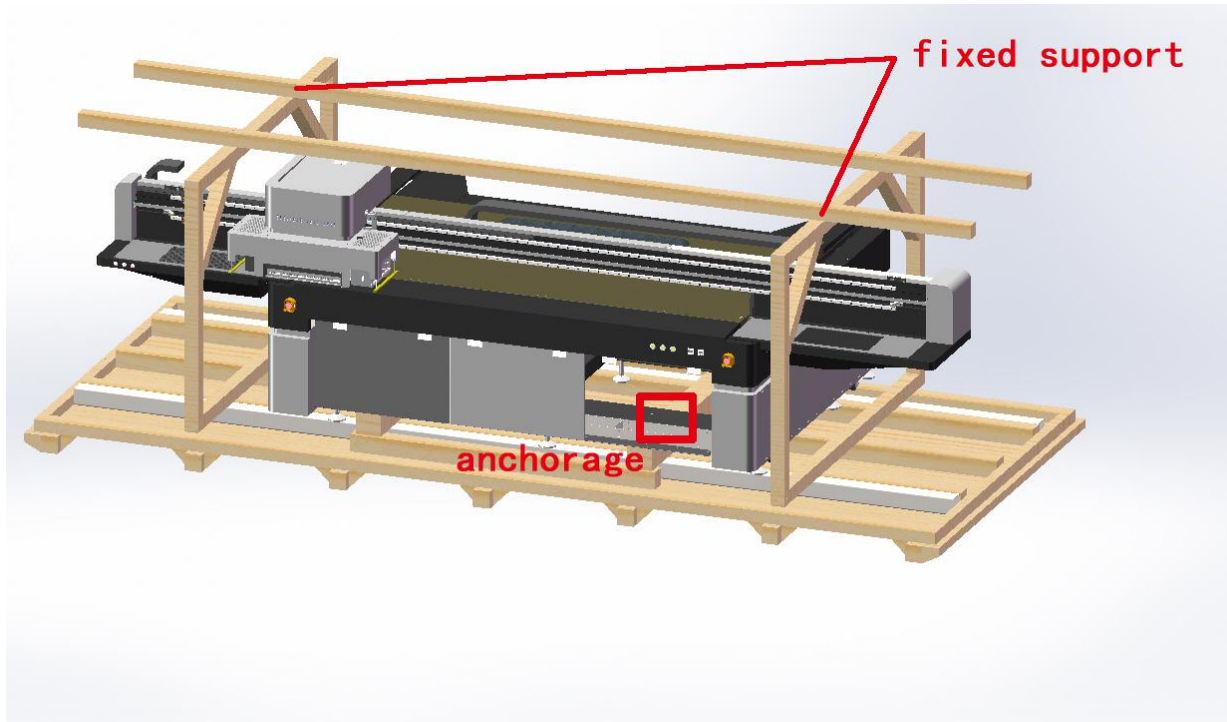

3. Please refer to the diagram effect by using the forklift to unload the machine. The operation shall be based on the actual conditions under the premise of ensuring stable unloading. (Forklift arm of KC2512 > 1900mm, forklift arm of KC3020 > 2650mm.)

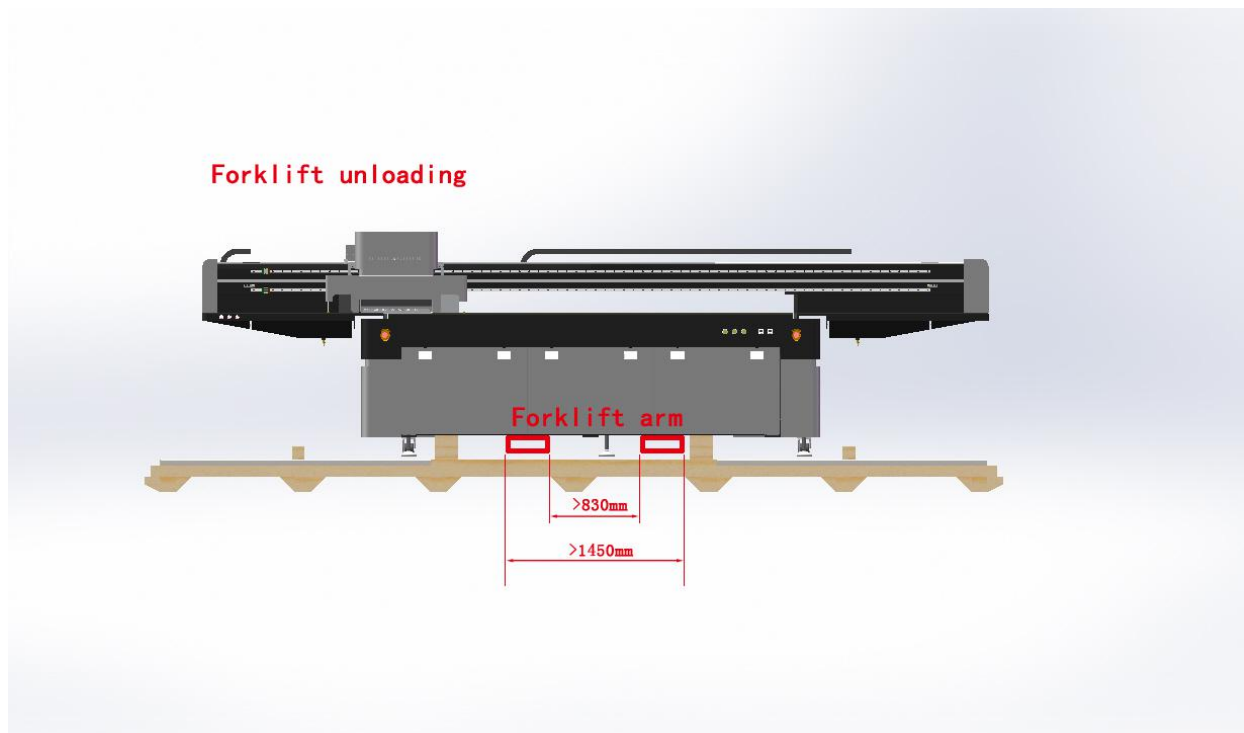

4. Leveling machine. Place the machine in the working area, raise the leg. The universal wheel shall be suspended. Select the level with sensitivity higher than 0.05mm/m to adjust the legs at the corner of the

frame 4, which can make the level precision of the red area shown in the small figure can reach within 0.1mm/m.

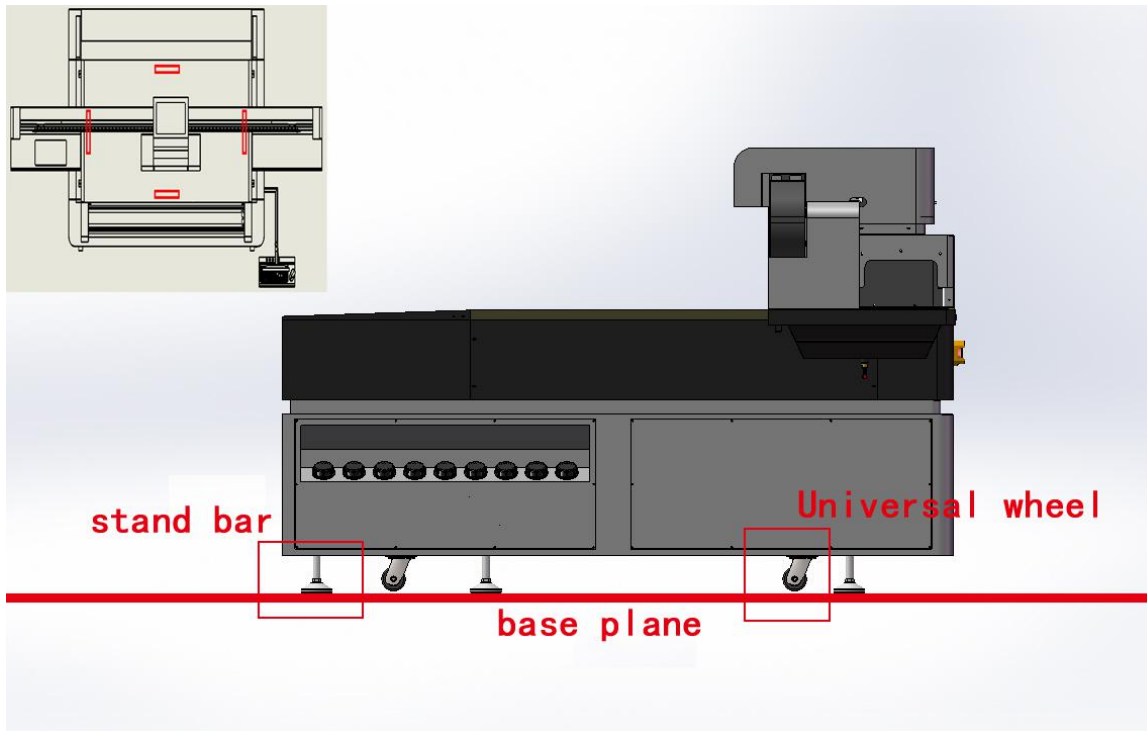

5. Adjustment of the platform. Check and adjust the platform flatness of each newly installed KC machine. The legs and the platform adjusting bolts shall be adjusted with the bolts are located inside the machine under the platform. The error of each adjustment point of each platform shall not exceed  $\pm 0.15\text{mm}$ .



● *Appearance, name and functions of parts*

■ **KC\_2512 Front view**

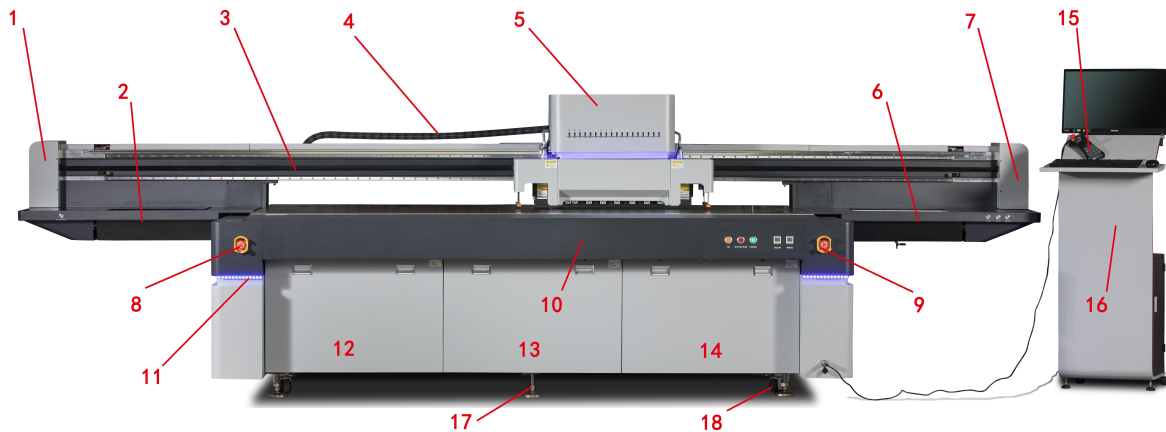

Code	Name of parts	Description
1	Left shell	The transmission tension components are installed inside on

		<b>the direction of car scanning.</b>
<b>2</b>	<b>Left shading box</b>	<b>This location is for cleaning and maintenance, as well as for carriages' idle parking. The left shading box includes: ink collecting plate, cleaning and maintenance panel and LED for lighting. The push of the ink collecting drawer can switch on/off LED light.</b>
<b>3</b>	<b>Girde</b>	<b>Equipped with 2 linear guides to support carriage X scanning. A grating is fitted to the car for positioning.</b>
<b>4</b>	<b>Cable carrier</b>	<b>The main function of the cable carrier is to guide the cable, pipe, ink tube and other functional lines.</b>
<b>5</b>	<b>Carriage</b>	<b>The carriage contains print head, circuit board, triple-valve body and other components.</b>
<b>6</b>	<b>Right light shield</b>	<b>It can provide shading when the carriage runs to the right, with a drawer designed for storing commonly used items (weight &lt; 3kg). Due to the habits of customer in various regions; ink-pressing cleaning button is also set on the right of the machine.</b>
<b>7</b>	<b>Right casing</b>	<b>The motor assemblies are installed inside on the direction of scanning.</b>
<b>8</b>	<b>Emergency stop switch 1</b>	<b>Press it in emergency.</b>
<b>9</b>	<b>Emergency stop switch 2</b>	<b>Press it in emergency.</b>
<b>10</b>	<b>Front casing</b>	<b>The front casing contains the function buttons of “Starting”, “Medium Positioning” and “Print Head High Pressure”. Negative pressure meter 1 (color); Negative pressure meter 2 (white).</b>
<b>11</b>	<b>Atmosphere light strip</b>	<b>(Optional).</b>
<b>12</b>	<b>Front panel 1</b>	<b>Open it to observe the platform adsorption system and internal platform adjustment mechanism.</b>
<b>13</b>	<b>Front panel 2</b>	<b>Open it to observe the platform adsorption system and internal platform adjustment mechanism.</b>
<b>14</b>	<b>Front panel 3</b>	<b>Open it to observe the platform adsorption system and internal platform adjustment mechanism.</b>
<b>15</b>	<b>Remote control handle</b>	<b>It can realize functions of shut downing the machine, the movement to X, Y, Z, automatic height measurement, platform partition adsorption and printing.</b>
<b>16</b>	<b>Computer control cabinet</b>	<b>(Optional) Operating computer and placing some tools.</b>
<b>17</b>	<b>Leg</b>	<b>Adjust the height of the platform.</b>

18	Roller	Move the machine and suspend when printing.
----	--------	---

**Diagram of the Remote Control Handle:**



Code	Name of parts	Description
1	Emergency button	Press it when shutting down or in case of emergency.
2	Motion control rocker	Control the movement in X, Y and Z direction.
3	Unlock button of X, Y movement	The rocker doesn't work when closed.
4	Press button	Select the print file on the software, and press the button



		to start printing automatically.
5	Platform positioning button	The positioning pin will pop up when clicking.
6	Automatic height measurement button	Measure the height of medium automatically.
7	Platform adsorption button	Adsorb the medium on the platform.
8	Adsorption air flotation switching	Switching of adsorption to air flotation can remove the printing media conveniently.
9	Adsorption partition	The platform is divided into several zones.

■ KC\_2512 Back View

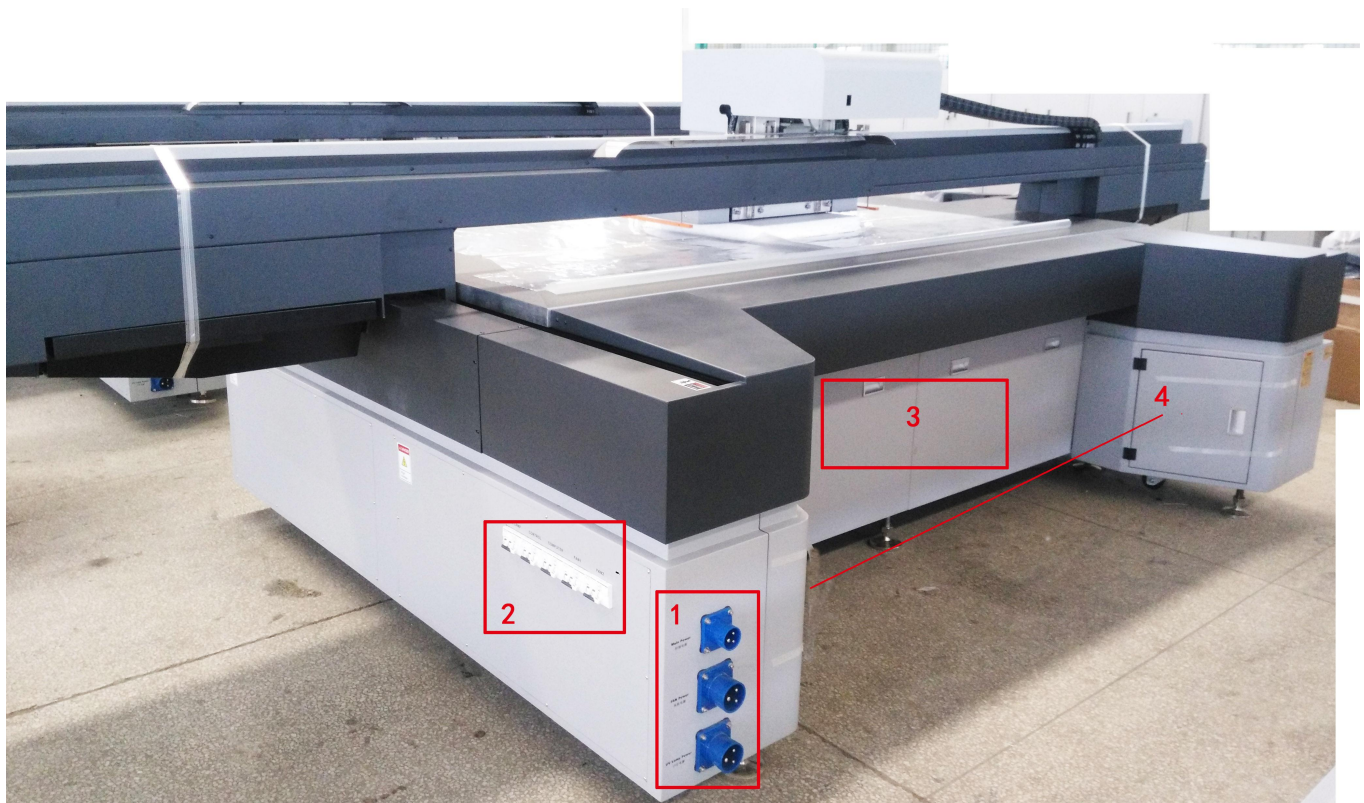

Code	Name of parts	Description
1	Power interface	Three interfaces: Main Power, FAN Power and UV Lamp Power.
2	Air switch	Control LAMP, CONTROL, COMPUTER, FAN1, FAN2, respectively.
3	Rear cover	Open to observe the internal conditions of the machine.
4	Back box	Store some necessary items.

## Diagram of Power Interface Diagram of Air Switch



### ■ Carriage view

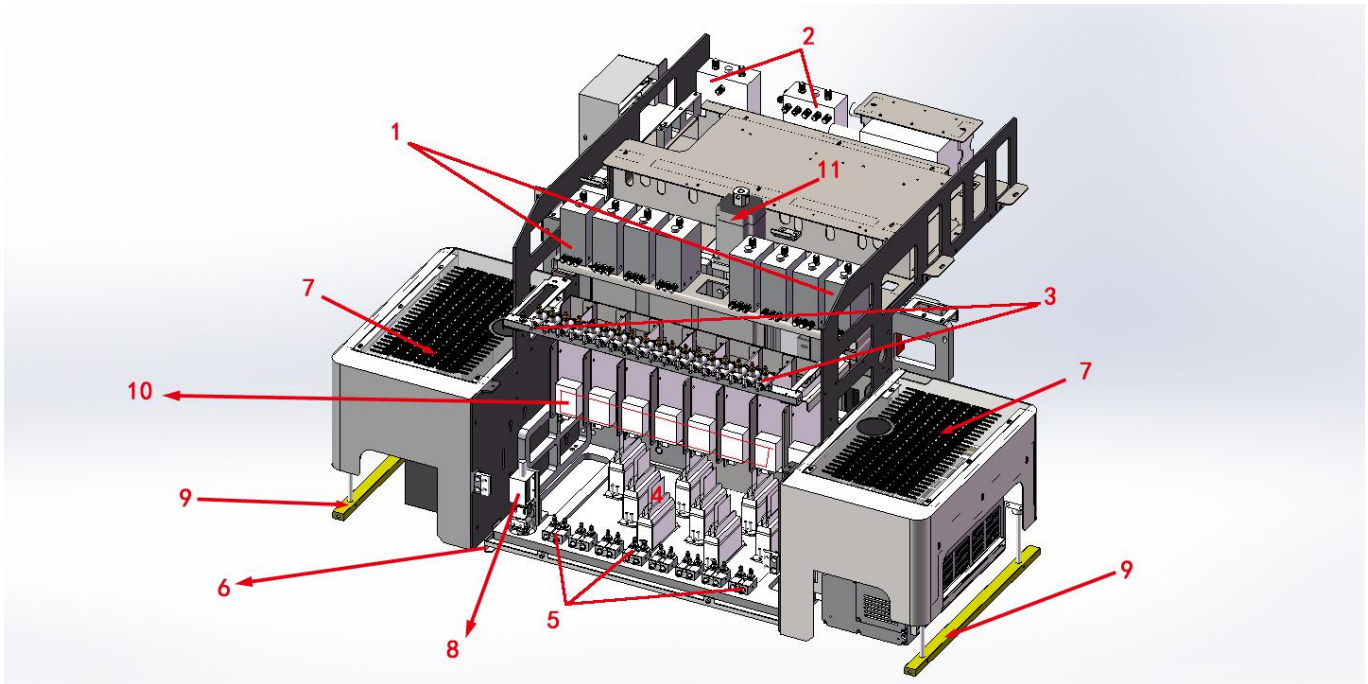

Code	Name of parts	Description
1	<b>Auxiliary ink tank</b>	Level 2 buffer negative pressure works as the ink in the main ink tank is filled to the auxiliary one.
2	<b>Waste liquid tank</b>	It's used for suck-back protection. The machine will stop working when the refluent ink flows to the waste liquid tank.

3	Three-way valve body assembly	Three states. It's used for printing, cleaning and closing.
4	Print heads	Deciding the numbers of print heads and putting them on right positions according to machine types.
5	Two-way valve body	It has two states, which can be used to discharge the gas in the print head.
6	Moisturizing tray	It is used for print head protection when the machine is power off.
7	Left/right UV lamp (including casing)	It is used to solidify UV ink.
8	Height measurement system	It's used for automatic measurement of medium height by handle operation and software operation.
9	Left/right collision protection switch	When hitting an exorbitant foreign object during printing, the carriage will stop and the switch will protect the machine.
10	Driver board for print head	Designed for Ricoh G5 print head.
11	Z lifting motor	To control the height of the print head.

The following pictures are details for three working statuses of the three-way valve body:

State 1: Working state, when the equipment is in normal operation, especially in printing, the valve shall be upward.

State 2: Cleaning state, when it's time to clean the print head with cleaning fluid, please place the valve downward.

State 3: Off state, when the equipment is shut down, place the valve in closed direction.

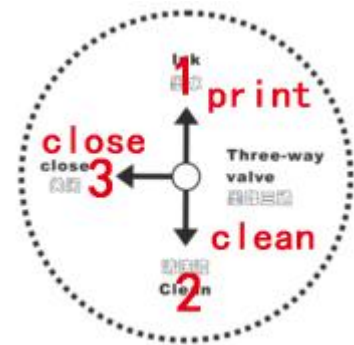

Two statuses of two-way valve assembly, explaining in detail:

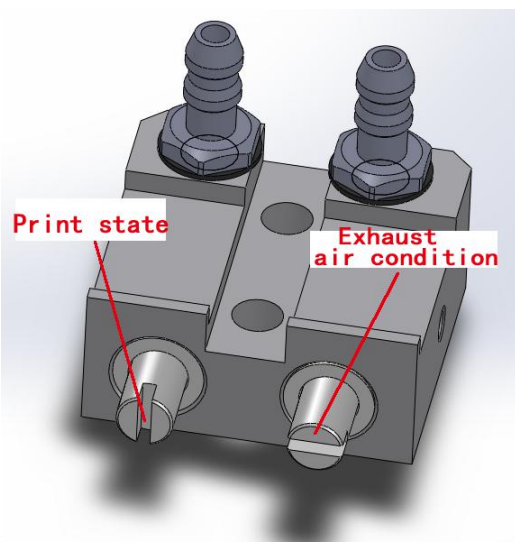

Print status: upon printing for daily work, the valve core is vertical and valve body is closed.

Air-extraction status: When it is required to extract the air out from print heads, making the valve core rotate 90°, pressing ink at the same time and reinstate the valve core in print status after the air is fully discharged.

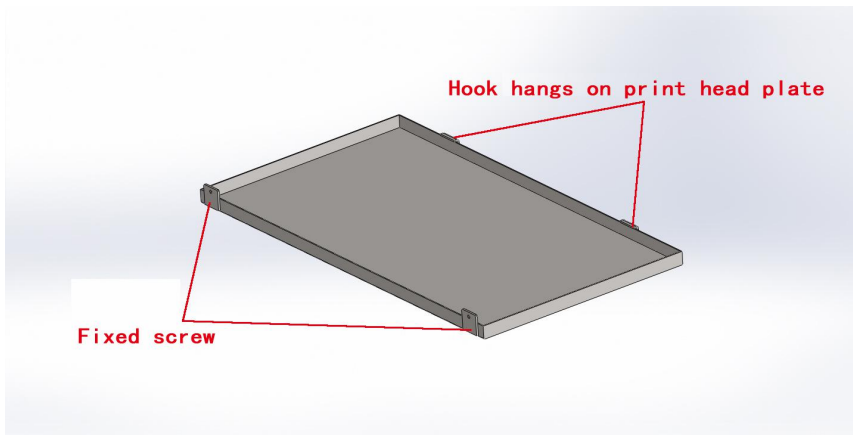

Usage mode of moisturizing tray: in the condition of power-off, the print head bottom board shall be covered by non-woven fabrics with cleaning solution, then be hung on the bottom of the print head floor and fastened by screws.

## ● Consumables

### ■ Printing Media

The common media for the inkjet printer include such commonly used media for advertising equipment as PVC, PMMA, glass and wall cloth. Please pay attention to the following matters as regards media purchase, storage, use and disposal:

- ✧ Inferior medium may reduce the printing quality, so it is suggested you select the high quality printing media.
- ✧ Do not store the media vertically so as to avoid clutter or damaged edge, especially for plate media, please place the plate media on flat surface and avoid any deformation of the plate.
- ✧ Do not preserve the media in the environment with great temperature and humidity changes, instead, the media shall be preserved in clean and tidy environment with proper temperature and humidity.
- ✧ Do not use the printing media with scratch, wrinkle, curl and surface bulge for the coiled material. The use of this kind of printing media may result in equipment failure or damage when printing.
- ✧ Ensure the clean and tidy printing surface of the media during printing, free from any dust and clutter, otherwise, equipment failure or damage may occur.

## ■ Ink and Cleaning Fluid

The print head of inkjet printer belongs to high precision equipment. Therefore, the ink quality will greatly affect the printing quality and the service life of print head. Please use the ink and cleaning fluid recommended by the manufacturer and pay attention to the following items at the same time:

- ◇ Failure to use the ink as recommended may cause lowered printing quality or equipment damage.
- ◇ The guarantee period of ink is six months in general (calculated from the production date), so please use the ink within guarantee period.
- ◇ Make sure that there is plenty of ink in main ink bottle during the working period of the machine.
- ◇ Ink should be kept in a shady and cool place.
- ◇ Since ink and cleaning fluid are strong acid or alkaline liquid, please store them properly and try to avoid skin contact, let alone swallow, and keep it away from eyes.

## ■ Maintenance Tools

Please use the cleaning fluid recommended by the manufacturer to clean the print head, moreover, use the specialized wiping paper recommended by the manufacturer to wipe the print head, otherwise, it may lead to the permanent damage to the print head.

## Chapter 2 Basic Operation

---

This chapter illustrates the basic actions of machine installation and operation. The main content of this Chapter:

- **Installation environment for PrintManager of KC\_Ricoh Series**
- **Installation steps of PrintManager**
- **Installation and adjustment of print head**
- **Introduction of Ricoh G5 print head**
- **Print head installation**
- **Power ON/OFF of the Machine KC\_Ricoh**
- **Power ON**
- **Power OFF**
- **Add ink and fill the print head with ink**
- **Inject ink into the main ink tank**
- **Inject ink into the auxiliary ink box**
- **Fill the print head with ink**
- **Positive pressure ink**
- **Negative pressure adjustment**

## ● *Computer connection*

### ■ Installation environment for PrintManager of KC\_Ricoh Series

1. Please apply Win7 64bit operating system.
2. To guarantee the operation of the software, please install the application environment Microsoft .NET Framework4 of the software first.

### ■ Installation steps of PrintManager

Find the PM software in the CD, and double-click "set up.exe".

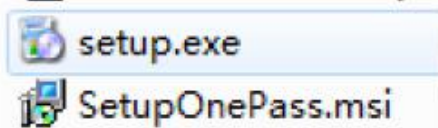

Double click the "set up.exe" program to start the installation and the interface as shown below will pop up.

the "set up.exe" program to start the installation and the interface

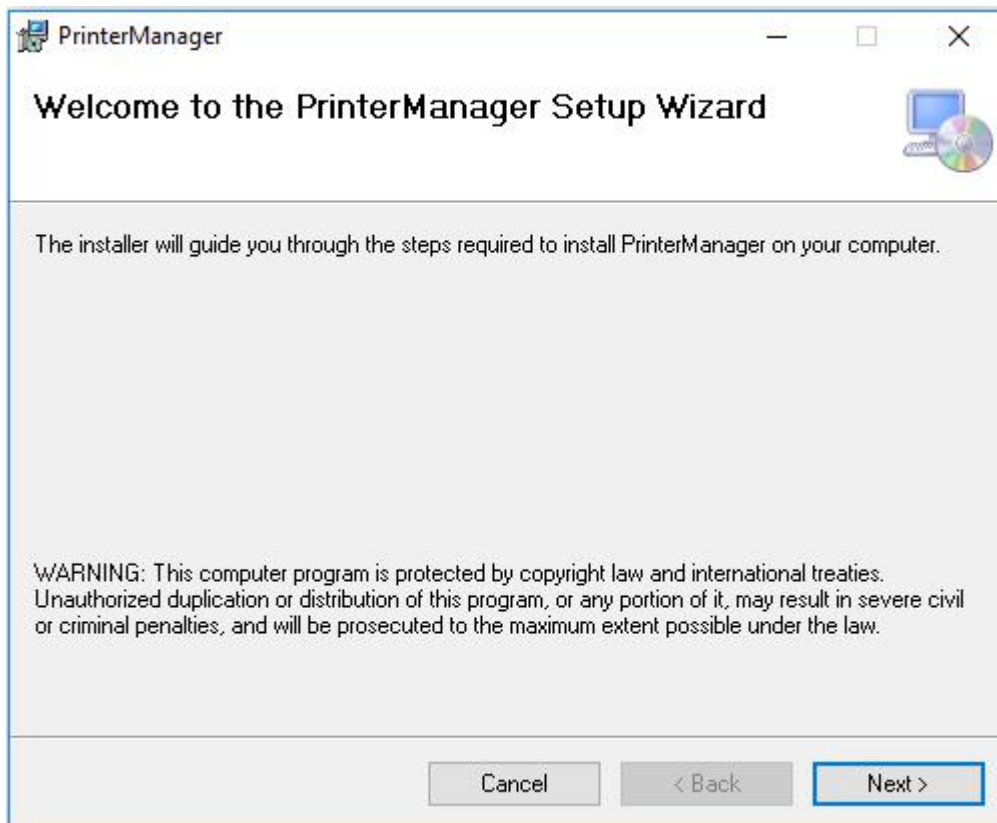

Click "Next" to go to the next step, as shown below:

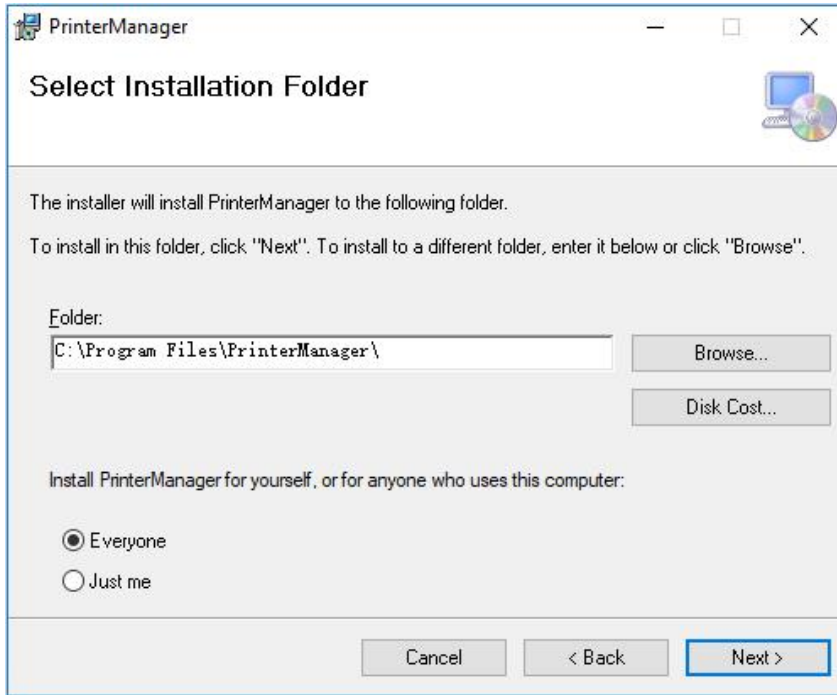

This step is to select the installation path (default settings are recommended), click DiskCost to view the space size of the hard disk partition, the user selects Everyone in default, and then click "Next" to go to the next step, as shown below:

Confirm the page, and then click "Next" to go to the next step to install, as shown below:

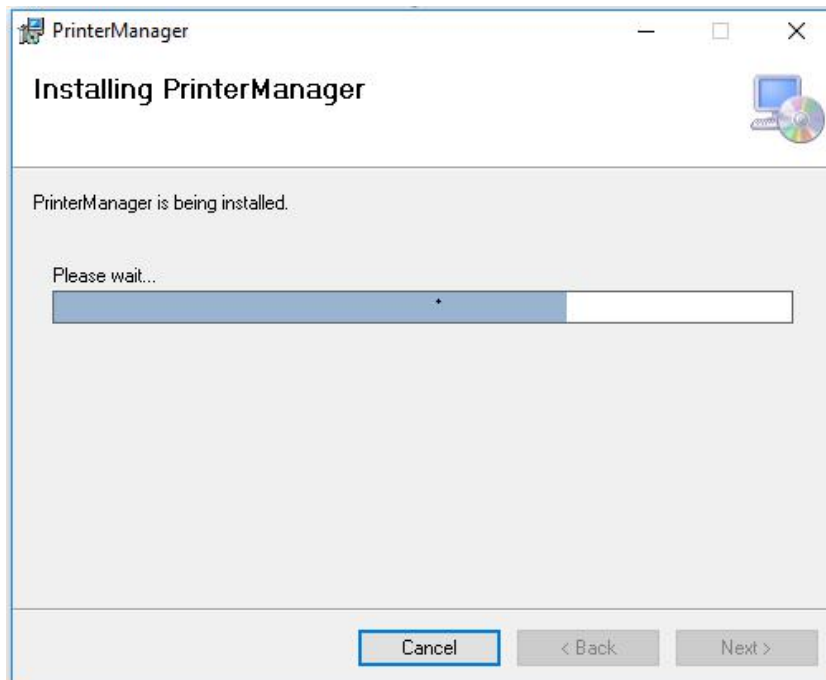



It takes a few minutes to install the software.

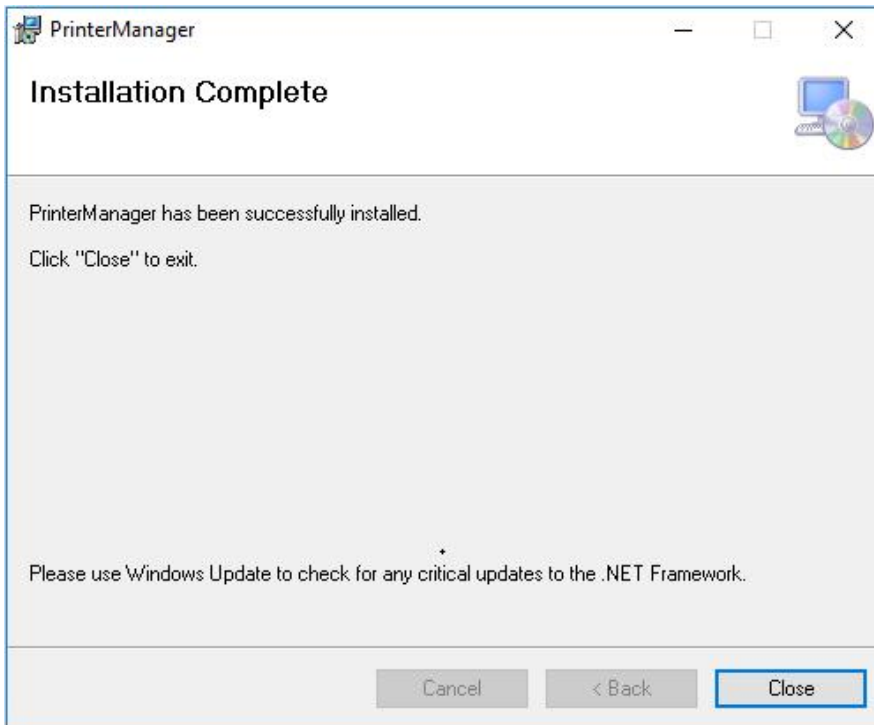

After the software is installed successfully, click "Close" to finish and exit installation.

Then connect the USB cable, start the machine, "BYHX Wide Format Printer" will be found in the "Device Manager" - "Universal Serial Bus Controller" of the computer, indicating that the Driver has been installed successfully. As shown below:

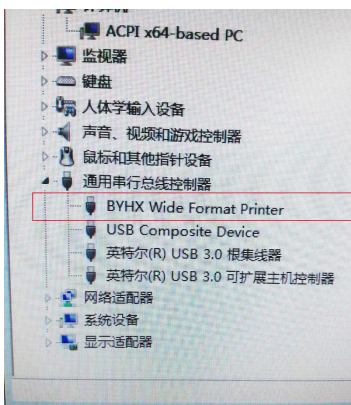

## ● *Installation and adjustment of print head*

---

### ■ Introduction of Ricoh G5 print head

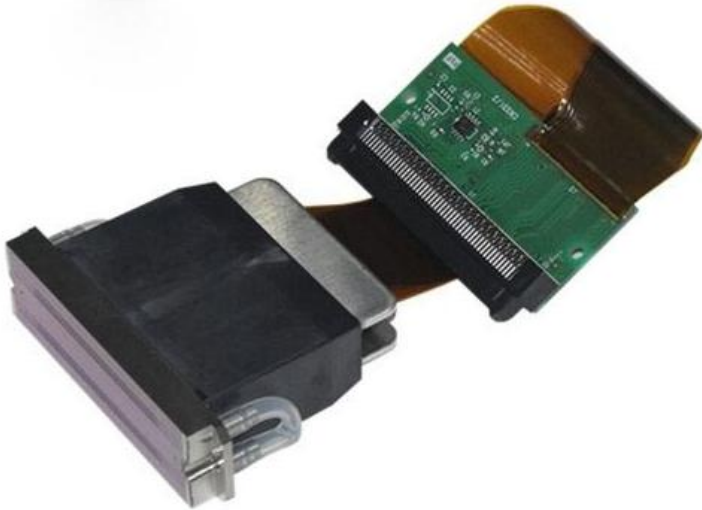

A high precision and high speed print head is widely used in the printer industry, and is also the most mainstream print head now supporting with 7PL ink dot and 4 level grayscale printing. There are two row of ink outlet at the bottom of G5 print head on each side, each row is divided into two groups, and each group has 320 nozzles, and a print head has  $320 \times 4 = 1280$  nozzles in all.

### ■ Print head installation

1. Place clean non-woven fabrics under the bottom plate of print head, so as to avoid soiling nozzle panel or blocking nozzle during print head installation process.
2. Please unpack the print head as careful as possible to avoid damaging it.
3. The following figure is the installation diagram:

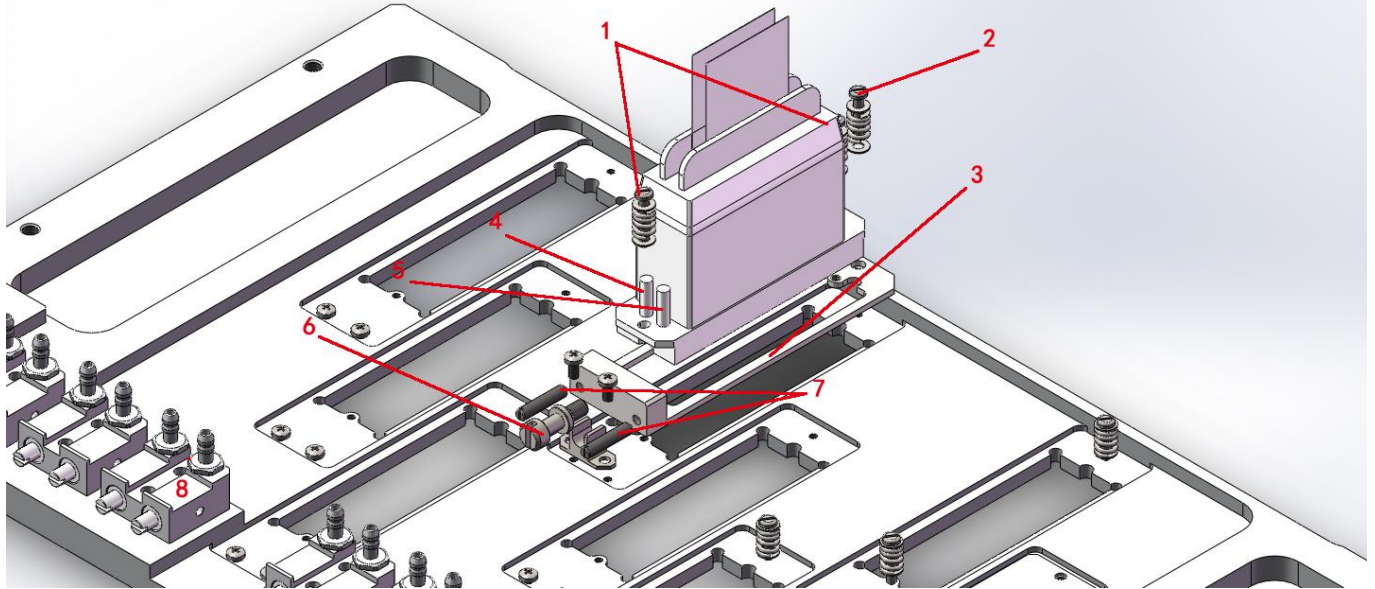

Installation Diagram a of Print Head Ricoh G5

Code	Name of parts	Description
1	Mounting screw for print head	Fix the print head on the adjusting support
2	Mounting screw for adjusting support	Fix the adjusting support
3	Adjusting support for print head	To adjust the physical position of the print head
4	Ink outlet 1	Connecting the two-way valve body for exhausting air
5	Ink outlet 2	Connecting the two-way valve body for exhausting air
6	Vertical adjusting screw for print head	To adjust the front and back physical position of the print head
7	Inclined adjusting screw for print head	To adjust the inclined physical position of the print head
8	Two-way valve body	To keep pressure differential and exhaust air inside the print head.

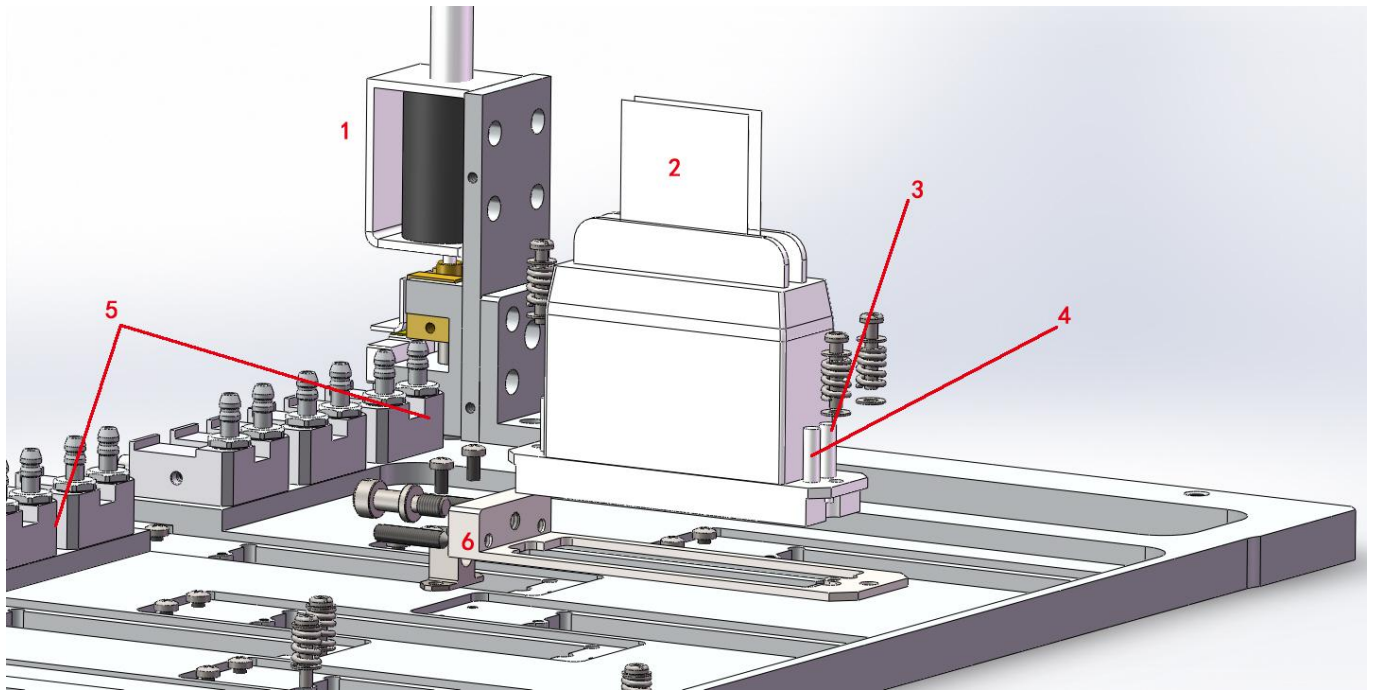

Installation Diagram b of Print Head Ricoh G5

Code	Name of parts	Description
1	Height measurement system	To measure the height of printing media
2	Print head cable	Connect the driver board for print head
3	Ink inlet 1	Connect the three-way valve body
4	Ink inlet 2	Connect the three-way valve body
5	Two-way valve body	To keep pressure differential and exhaust air inside the print head.
6	Adjusting support	To adjust the physical position of the print head

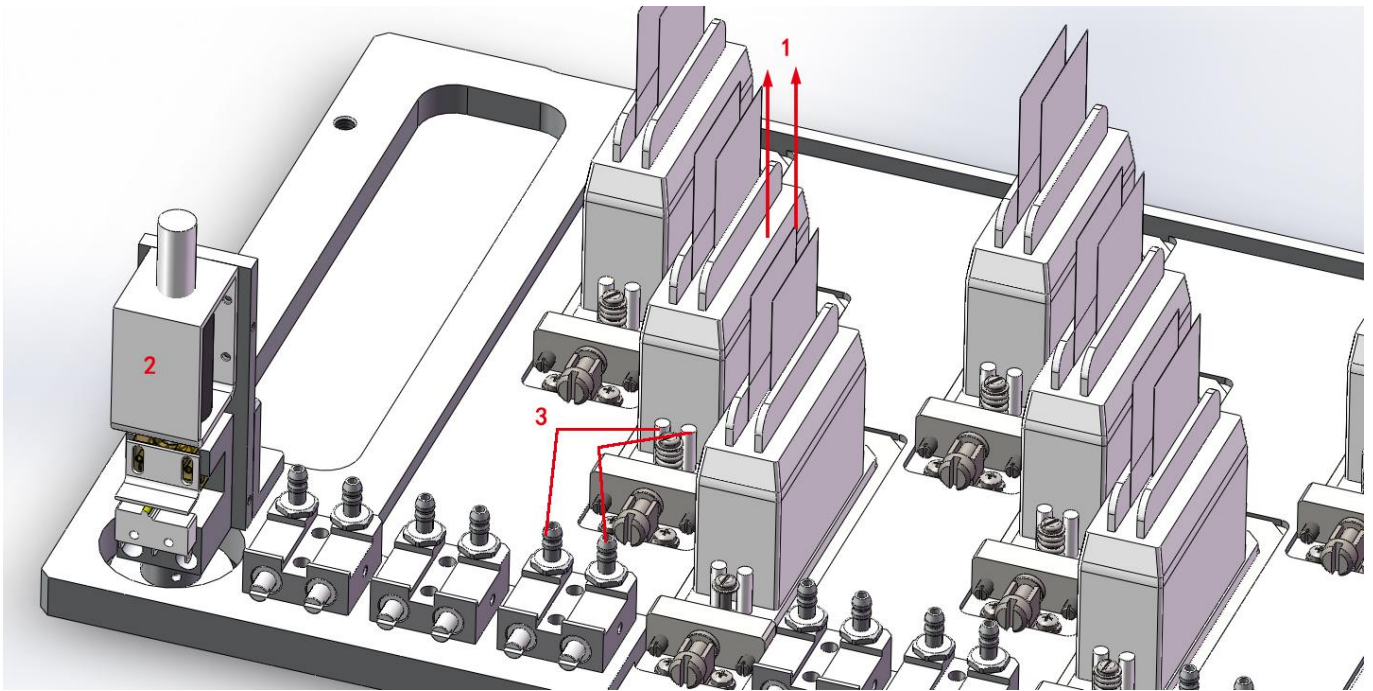

Installation Diagram of Print Head Ricoh G5

Code	Name of parts	Description
1	Ink inlet connecting the three-way valve joint mouth	The ink enters into the print head through the three-way valve body
2	Height measurement system	To measure the height of printing media
3	Ink outlet connecting the two-way valve joint mouth	To exhaust the air and waste ink inside the print head

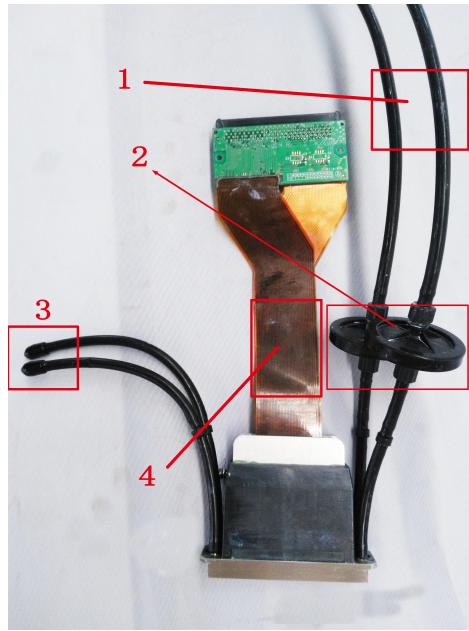
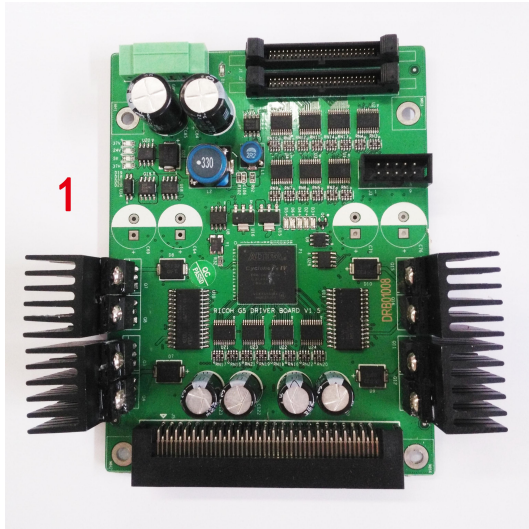

Code	Name of parts	Description
1	Driver board for print head	To provide the voltage and data required by the print head
2	Connecting the three-way valve body assembly	The ink enters into the print head through the three-way valve body
3	Butterfly filter	Filter the impurities of the ink
4	Connecting the two-way valve body	To exhaust the air and waste ink inside the print head
5	Print head cable	Connect the driver board for print head

Please use the special mounting screw provided in the fitting box to fix the print head, winding the USB cable by using the acetate insulated rubber tape before installation to protect it before installation.

**Effect Picture after Installation:**

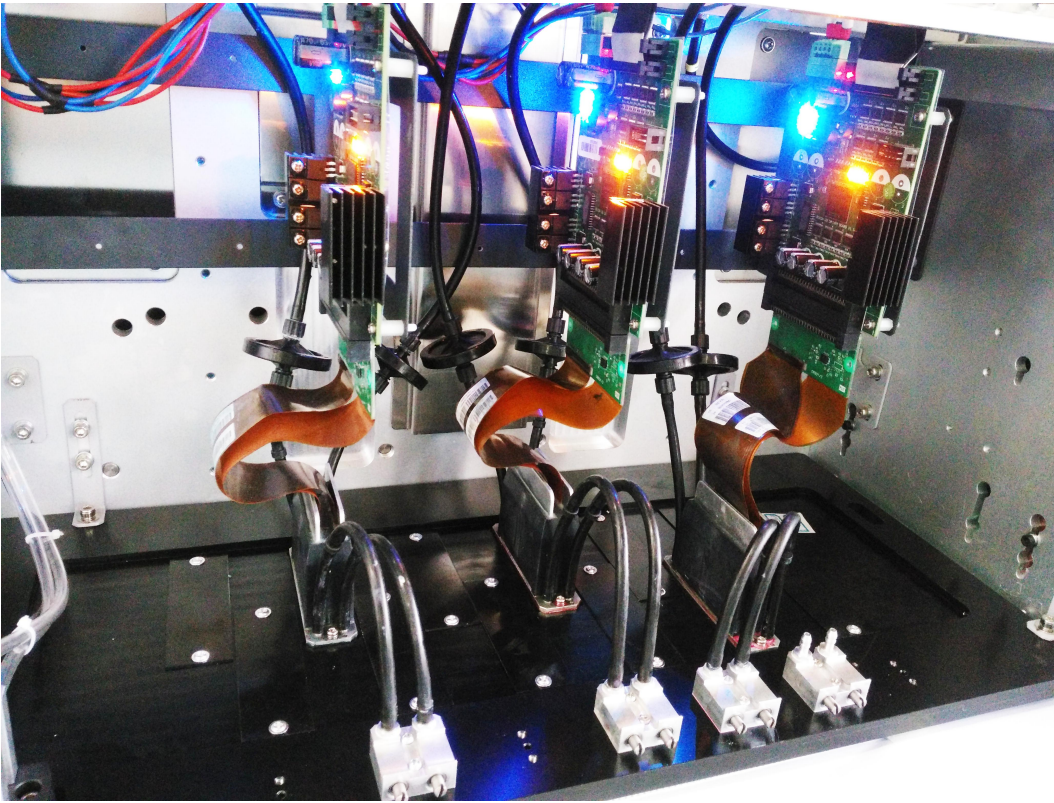

- ***Power ON/OFF of the Machine KC\_Ricoh***

---

- **Power ON**

**Please pay attention to the foreign object on the platform when starting KC, move the carriage to the right of the girde (location of flash work), and the gride will stay at the front of the machine platform. Turn the Emergency Stop Switch, click the Start button and the machine will run self-inspection. The self-inspection process is accompanied by the beating of the negative pressure solenoid valve and the working sound of the ink pump. The machine KC will start to work after self-inspection and connection. Don't press "Fix" button when power on, otherwise, the machine will not run self-inspection normally.**

- **Power OFF**

**The machine shall be powered off after the work completed. Firstly, press the ink to confirm that all nozzles are smooth, move the carriage to the right flask work position, close the three-way valve body, and add the moisturizing tray, press the Emergency Stop Switch. The inside of the moisturizing tray shall be kept clean.**



- *Add ink and fill the print head with ink*

- **Inject ink into the main ink tank**

You can find the inking port of the main ink box on the left side of the machine. Please infuse ink in accordance with the colors marked on the main ink boxes. The following is schematic diagram:



- **Inject ink into the auxiliary ink box**

Before injecting ink into the auxiliary ink box, make sure that there is enough ink in the main ink box.

Ensure that there is enough ink in the main ink bottle and conduct inspection of the machine before starting;

When energizing the printer at the first time, auxiliary ink boxes are empty, so ink pumps of different colors will work automatically to pump ink from main ink boxes into auxiliary boxes;

When all the ink pumps stop working, it means all the auxiliary ink tanks have been injected with ink;

The transient buzzer sound during the process may be resulted from rather long ink pump route and timeout;

In the event of ink pump not working or prolonged alarming of buzzer, please switch off the machine in time and examine. In case of failure to settle the problem, please contact the local dealer or after-sales department of our company immediately.

### ■ Fill the print head with ink

Since it is a very important operation to inject ink into the print head, please operate in strict accordance with requirements. There are two critical operations, namely print head cleaning and venting.

Print head cleaning:

The new print head must be purged with cleaning fluid before being injected with ink for the first time because protective liquid has been injected into the nozzle of print head, so the ink can only be injected into until the protective liquid being cleaned.

In view of the power of cleaning fluid pump, it is suggested that you clean a single print head every time. First, put the three-way valve of single print head at purging state with other print head valves off, then unscrew corresponding two-way valve, the cleaning fluid will flow out from the two-way valve through the ink chamber of the print head. About one or two seconds later, tighten two-way valve and make the cleaning fluid cascade out from nozzle for about five seconds. Clean other print heads according to the above method. After five minutes, clean all the print heads again as per the above method.

Venting of print head:

Inject ink into the print head after cleaning print head. Venting operation shall be conducted together with ink injection with the specific operation process as follows:

1. It is also suggested that you conduct venting for every single print head, that is to say, venting operation is conducted for only one print head every time with valve body of other print heads off.

First of all, put the corresponding three-way valve body in a working state.

2. Unscrew the corresponding two-way valve core to ensure a smooth ink outlet. Press positive pressure button and impress ink from the auxiliary ink tank into the print head, then ink will flow out from two-way valve core. Observing the flow state of the ink from the ink outlet and closing the two-way valve as a blast of the ink falls plumb down without air bubbles, then the ink flows out from the jet orifice. (Tips: it may takes long to impress ink for the first time with such long pipelines, moreover, there is no sufficient ink in the auxiliary ink tank, please hold on for a while after positive pressure so as to enable ink supply system to refill the auxiliary ink tank and then continue positive pressure);
3. Carry out the above operation for every print head in succession. Place all three-way valves of the ink path in

working state after completing venting for all print heads. Press positive pressure button and impress ink for all colors again, then complete ink injection of print heads.

4. Meanwhile, in case of bubble found in ink tube leading to print head, which affects ink out of the print head, the above method can also be adopted to carry out venting operation.

## ● *Positive pressure ink*

---

Positive pressure ink refers to impressing ink of the auxiliary ink tank into the print head by pressing positive pressure button, flush through the nozzle blocked not so seriously and eliminate the air in the print head, as well as solve some common problems of printing disconnection. You can impose positive pressure to either a single print head or several or all print heads with the specific operation steps as follows:

- ✧ Pushing the carriage to the non-operating position, i.e. the leftmost of the machine.
- ✧ Making sure that the ink-path three-way valve corresponding to the print head required to press ink stays in the state of working; the ink-path three-way valves corresponding to other print heads shall be rotated to the closing state if other print heads are on the same color.
- ✧ Rotating the air-channel three-way valve according to each color to the state of the positive pressure.
- ✧ Press positive pressure button and hold for a while, observe the ink out status of print head and release positive pressure button when you feel ink flowing smoothly.

Wait for two seconds and wipe the nozzle surface with clean non-woven fabrics.

## ● *Negative pressure adjustment*

Since negative pressure is an important parameter for guarantying print quality, the operation of its adjustment is crucial. The target of adjustment is to make ink form meniscus in every nozzle printer. As long as sound meniscus is maintained, we can assure that ink droplets are ejected at a high speed with few flight drops. Vacuum negative pressure system is applied to KC to control the ink droplet.

### **Introduction to the vacuum negative pressure system:**

The foregoing section has introduced that two-way negative pressure design is provided for KC series products. One is for colorful print heads and the other is for white print heads. However only one-way negative pressure design for solvent products. The reason of this design is that there is a larger difference between the viscosity of the white ink and

that of others, so an exclusive negative pressure control is provided for the white, with the purpose of achieving better printing quality.

### Introduction to the vacuum pressure switch (negative pressure gauge):



The vacuum pressure switch is shown in the figure, and the function of each area is introduced as follows:

<b>1: Pressure display area</b>	<b>It displays the current pressure in the vacuum tank</b>
<b>2: Setting pressure display area</b>	<b>It displays the set pressure value</b>
<b>3: Signal output prompt</b>	<b>It prompts the current output states of UT1 and OUT2</b>
<b>4: Button operation area</b>	<b>MODE: Mode setting, the up and down keys are used for setting values or turning pages</b>

Note: Please refer to reference file 2 for detailed operation of the vacuum pressure gauge or read the manual of the vacuum gauge.

### Vacuum negative pressure adjustment

Corresponding parameters have been set when the machine leaves the factory. However, the set valves may be needed to be micro-adjusted accordingly according to the local environment. You may adjust negative pressure value setting as per the following method:

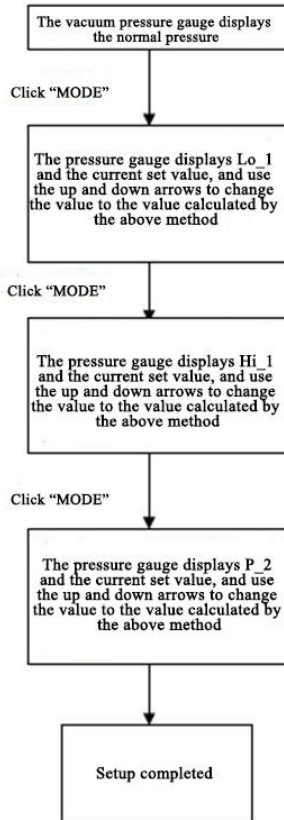

The above is the setting method for setting value in differential mode, and the setting method in EASY mode is similar. But you only need to set values of P-1 and P-2. For more details, please refer to detailed operation of vacuum pressure gauge.

# Chapter 3 System Function

---

Contents of this chapter:

- **Introduction to KC\_Ricoh\_G5 Ricoh System Function**
- **Core component**
- **PC**
- **Main Board**
- **MAP Board**
- **HB Board**
- **Ricoh G5**

## ● Introduction to KC\_Ricoh\_G5 Ricoh System Function

### ■ Core component

The core part of the KC Ricoh system is made up of PC + Main board + MAP board + HB board + Ricoh G5, as shown below:

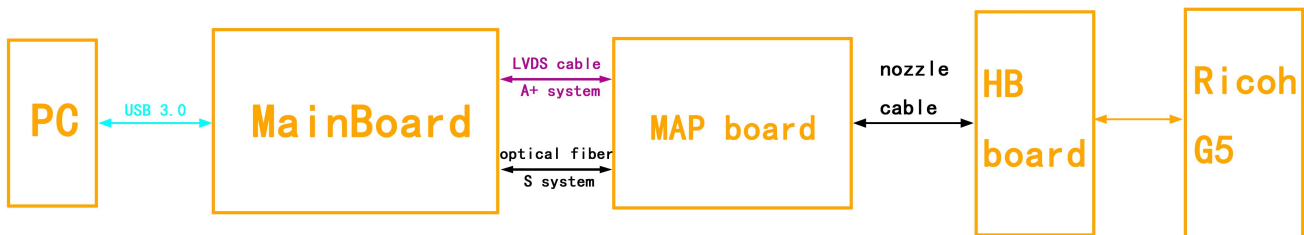

The five parts are described below.

### ■ PC

To guarantee the computer and the chassis grounding wire conform to the specifications.

### ■ MainBoard

The MainBoard is the core of KC, all commands and actions are given by the MainBoard. Currently, the MainBoard of KC has two types using A+ system, as shown below:

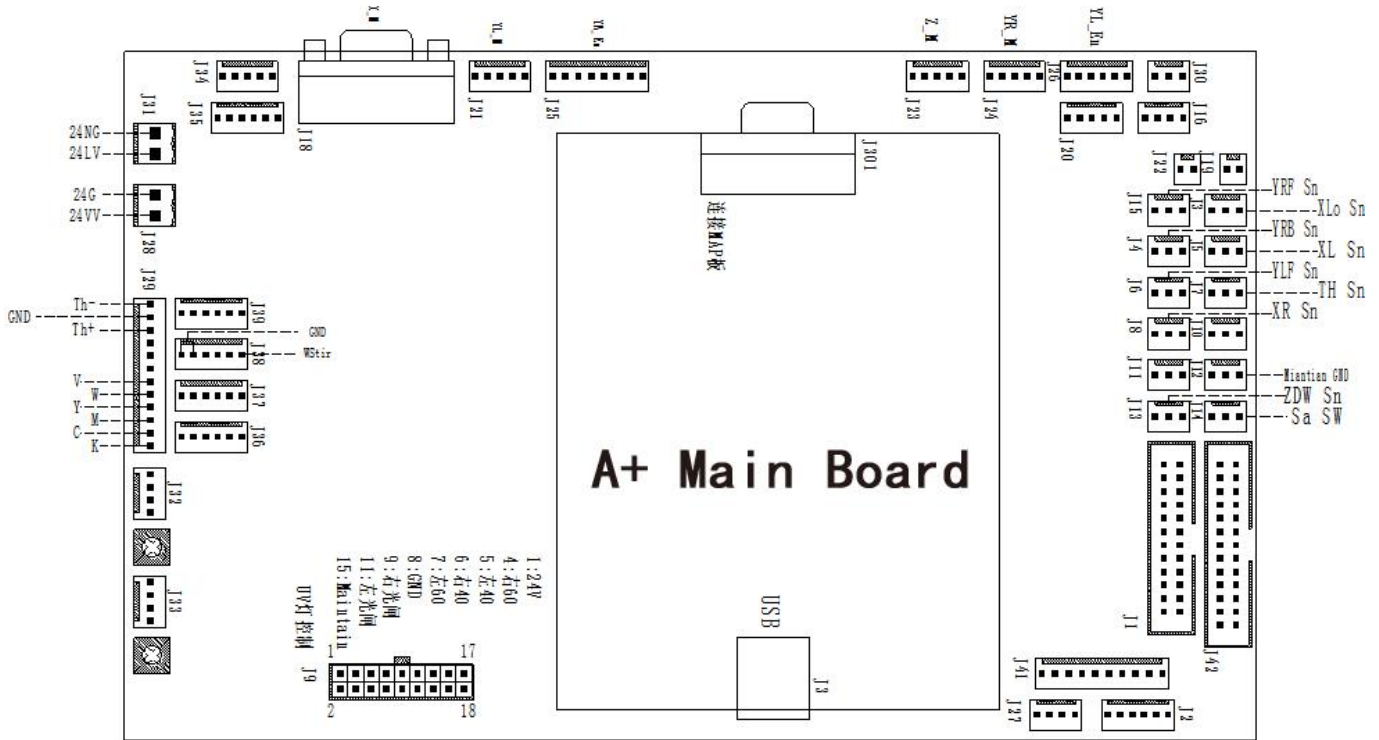

- |                     |   |
|---------------------|---|
| J15: YRF Sn         | Y Right front limit sensor                |
| J3: XL0 Sn          | Platform cylinder positioning sensor      |
| J4: YRB Sn          | Y Right rear limit sensor                 |
| J5: XL Sn           | X Left limit sensor                       |
| J6: YLF Sn          | Y Left front limit sensor                 |
| J7: TH Sn           | Height measurement sensor for print head  |
| J8: XR Sn           | X Right limit sensor                      |
| J9: UV Lamp control | UV Lamp control                           |
| J12: Maintain GND   | Maintenance function of print head        |
| J13: ZDW Sn         | Z Limit sensor                            |
| J14: Sa Sw          | Anti-collision switch for carriage        |
| J26: YL_En          | Y Left motor encoder feedback signal      |
| J24: YR_M           | Y Right motor control signal              |
| J23: Z_M            | Z Motor control signal                    |
| J301:LVDS Cable     | LVDS Line connector, connecting MAP board |
| J25: YR_En          | Y Right motor encoder feedback signal     |
| J21: YL_M           | Y Left motor control signal               |
| J18: X_M            | X Motor control signal                    |
| J27: TRX            | Handle control board                      |

Use the S system, as below:



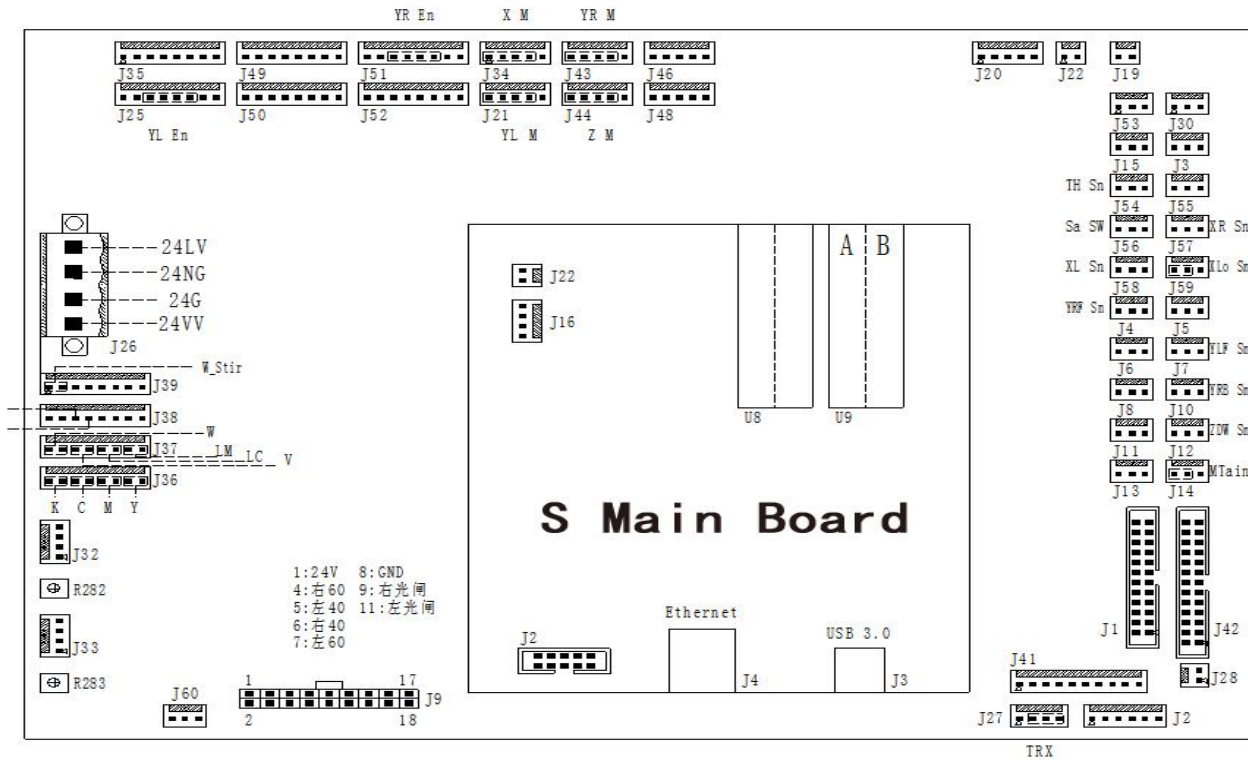

- |                     |                                       |
|---------------------|---------------------------------------|
| J54: TH Sn          | Height measurement sensor             |
| J56: Sa Sw          | Anti-collision switch for carriage    |
| J57: XR Sn          | X Right limit sensor                  |
| J58: XL Sn          | X Left limit sensor                   |
| J59: XLo Sn         | Platform cylinder positioning sensor  |
| J58: YRF Sn         | Y Right front limit sensor            |
| J7: YLF Sn          | Y Left front limit sensor             |
| J10: YRB Sn         | Y Right rear limit sensor             |
| J12: ZDW Sn         | Z Limit sensor                        |
| J14: Maintain       | Maintenance of print head             |
| J27: TRX            | Handle control board                  |
| J34: X_M            | X Motor control signal                |
| J44: Z_M            | Z Motor control                       |
| J43: YR_M           | Y Right motor control signal          |
| J21: YL_M           | Y Left motor control signal           |
| J51: YR_En          | Y Right motor encoder feedback signal |
| J25: YL_En          | Y Left motor encoder feedback signal  |
| J9: UV Lamp control | UV Lamp control line                  |
| U9: Optical fiber   | Optical fiber socket (A and B)        |

## ■ MAP Board

**MAP Board transfers the data received by the MainBoard to HB Board until print head, and transfers the feedback data from the print head, granting signal and liquid level signal data to MainBoard until PC.**

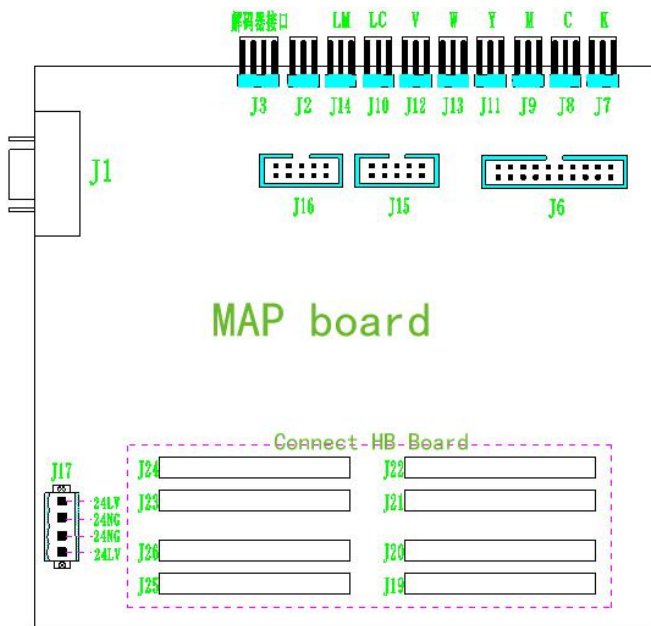

**J1:** Adopt the LVDS line guided by A+ system connecting with the MainBoard, adopt the S system connecting the LVDS line from the optical fiber adapter plate.

#### ■ HB Board

As the driver board for print head, HB Board plays a role in driving the print head, providing with voltage and data needed by the print head.

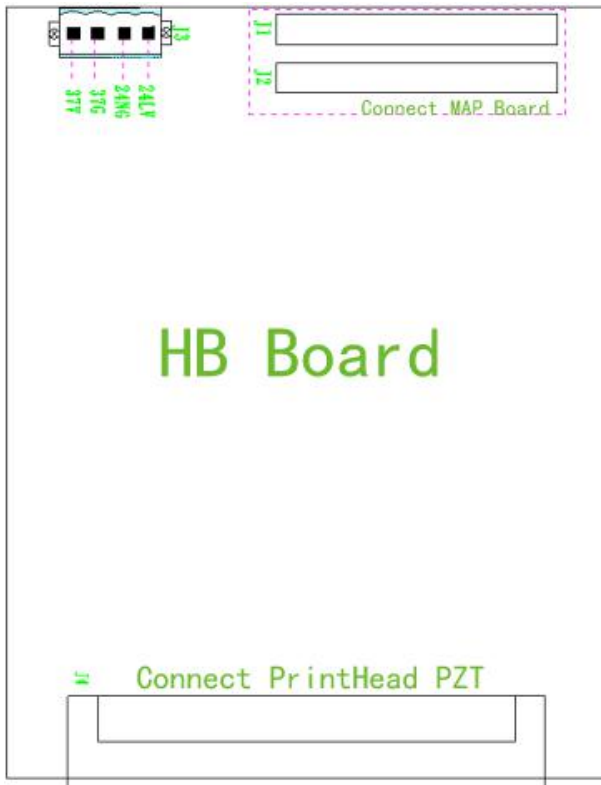

## ■ Ricoh G5

The print head is the last link of printing on medium by the ink droplet in the system, therefore, the voltage and temperature of the print head must be set correctly according to the temperature and humidity of the environment, so that the perfect ink droplet can be printed.

## Chapter 4 Maintenance and Service

---

Contents of this chapter:

- **Daily maintenance instructions**
- **Print head maintenance instructions**
- **Ink use guidelines**

## ● *Daily maintenance instructions*

---

1. Keep the working environment of the printer clean and ventilated, and clean dust and ink on the printer periodically;
2. Keep the work surface clean. Every time before starting it up, check whether the working board is cleaned, to avoid scratching the print head;
3. Inject lithium base greases into the slider by grease gun every forty hours operation, to reduce its frictional resistance against the guide rail and extend its service life;
4. Maintain an appropriate belt tightening of the ink carriage timing belt. The belt tightening of the ink carriage timing belt can be adjusted after removing the upper left end cap. After the adjustment, connecting screws must be fixed tightly;
5. Every time after finishing refilling ink, make sure the cover of the main ink tank is screwed tightly. Wipe off residual ink on the outer wall of the tank;
6. For positive pressure printing, after wiping the print head, flash spray for around 10 seconds first before printing pictures, to achieve sound meniscus formed by ink droplets in the nozzle;
7. The area around the orifice must be maintained clean. No residual ink, dust or fiber is allowed. Orifice shall not be scratched;
8. Since the ink and the cleaning fluid contain strong solvent, they mustn't contact electrical components and wires. Were ink or cleaning fluid spilled on them accidentally, they would be wiped off cleanly as soon as possible;
9. Clear liquid waste in the liquid waste box in time;
10. Every day before the startup and shutdown, it is recommended to print nozzle test chart to check whether the nozzle is in normal condition. Provided that ink outflows brokenly, press the ink or clean the nozzle to make it work properly.

## ● *Print head maintenance instructions*

---

As the core component, the print head is much expensive and sensitive, which requires good maintenance. Otherwise, print quality and its service life would be seriously affected. Print head maintenance instructions are as follows:

1. In using the printer, please use the ink appointed by the manufacturer. Do not change the ink at will, or it might lead to

malfunction of print head;

2. When the device stops running, maintenance methods of different sorts should be adopted in accordance with the length of downtime:

- ✧ If printer downtime is within a working day and you are not willing to turn it off, it should be set under the state of flash spray. Before the flash work, please confirm the status of print head. If it is not in a good condition, do the ink press operation first;
- ✧ If the downtime is over 12 hours to one day, it is recommended that the valve knob shall be screwed to the closed state, the ink carriage shall be stopped on the right light shield, power shall be switched off, a layer of non-woven fabrics shall be embedded into the moisturizing tray, a small amount of cleaning liquid shall be injected into the moisturizing tray (non-woven fabrics should be drenched), and then the print head can be moisturized with the moisturizing tray, during which operation make sure that the whole nozzle surface is in touch with cleaning liquid.
- ✧ If the downtime is within two days, the maintenance operations are the same as the previous one. Meanwhile, non-woven fabrics in the wet protection tray should be replaced every day, and new cleaning liquid should be injected into it (Cleaning liquid needs to be changed, because components of moisturizing function within it are easy to volatilize);
- ✧ If the downtime is over three days, clean up the ink within the print head following its cleaning method, inject a little cleaning liquid into it (Leave some cleaning liquid in the print head when doing the cleaning.) Meanwhile, moisturize the nozzle surface with the wet protection tray according to method 2. In addition, replace non-woven fabrics in the wet protection tray every two days and inject new cleaning liquid into it.

3. Scrubbing the nozzle panel

- ✧ Every time when pressing ink with positive press or after cleaning the print head, scrub the nozzle panel. Wipe away residual ink and cleaning liquid on the nozzle panel, to prevent it dropping onto the printer or print media;
- ✧ When scrubbing the nozzle panel, dedicated non-woven fabrics should be used, and make sure of its cleanness. Non-woven fabrics contaminated by dust, stain, oil or water, especially the one which has been used to scrub ink, should not be used to wipe the nozzle panel, as ink on it can lead to a seriously blocked nozzle;
- ✧ Scrub the nozzle panel along a single direction rather than back and forth. Do not scrub it with great strength, but touch it lightly, to avoid damage of nozzle surface;
- ✧ Dispose the used non-woven fabrics properly. Do not reuse it.

4. Adjusting the print head condition in printing

- ✧ To guarantee print quality, please make sure every nozzle on the print head is in good condition, whose condition can be improved by pressing ink with positive Negative pressure or doing the cleaning. The following items are

very important to guarantee the nozzle condition;

- ◇ The requirement of printer's working environment shall be maintained well, especially the temperature. The print head temperature shall be between 15 and 26 .Print quality may be affected if the temperature is below 15 or above 28 ;
- ◇ Make sure the print head exhaust completely, and no bubble remains in it;
- ◇ Adjust voltage and negative pressure of print head. A higher print head voltage can improve the accuracy and color saturation of ink droplets, but it can cause the ink outflow to be frequently broken as well, so the best balance shall be adjusted.

## ● *Ink use guidelines*

---

### 1. Special Note:

**Any part of the ink or ink path shall not touch water or any solution containing water molecule, otherwise gel would come into being which will block the ink path and even the print head.**

### 2. Safety instructions:

**Some chemical substances contained in ink are of very low toxicity and irritation, which will irritate eyes and respiratory system and cause allergic reaction. Contact with ink can be effectively reduced with sound ventilating device and personal protective devices. When dealing with ink, acrylic gloves and work clothes should be worn. If ink spills onto the skin, it should be washed immediately with soap-suds. Eating, drinking and smoking are forbidden in the workspace.**

### 3. Storage of ink:

Ink should be stored in sealed containers and placed in a cool, dry place with good ventilation no long-period exposure to light (including indoor sunlight, illumination light, etc.) and with temperature of 10 ~40 . Although ink has a storage duration of 12 months, it recommended to use it up within 3 months. Pay attention to the production date. Out-of-date ink cannot be used. Ink viscosity is greatly affected by temperature and varies according to different seasons, especially in summer and winter, which would have influence on printing quality. In addition, ink producers would make adjustment in ink viscosity in keeping with seasons. Thus, you must see to it that you choose ink on the basis of actual environmental temperature.